

# Shield Tunnel

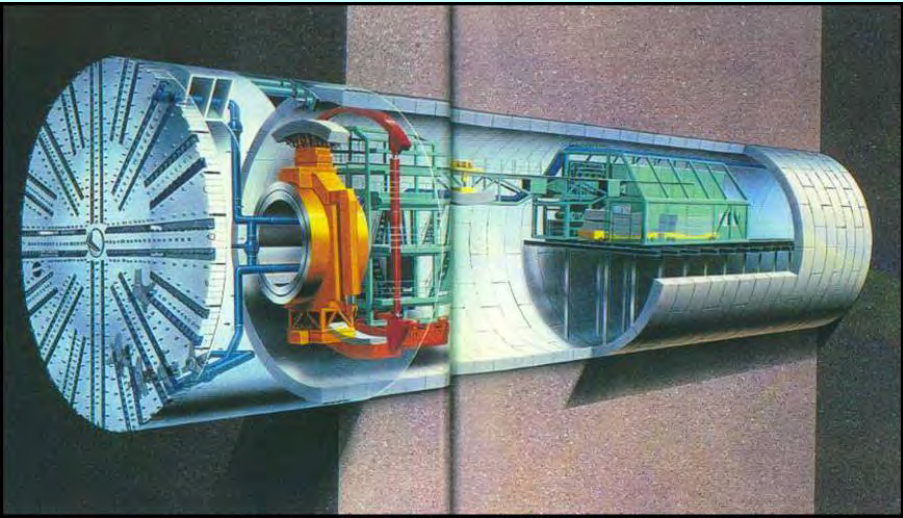

June 23<sup>th</sup> 2016 Lecture at Waseda Univ.  
Shinji KONISHI

# Types of Tunnel & Construction Methods

What's Tunnel?



What's a tunnel made of ?

# Types of Tunnel

# トンネルの種類

Cut & Cover  
Tunnel

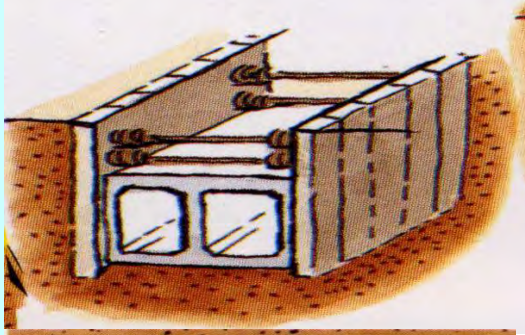

Shield Tunnel

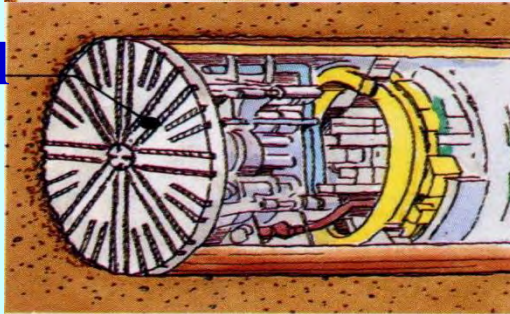

Mountain  
Tunnel

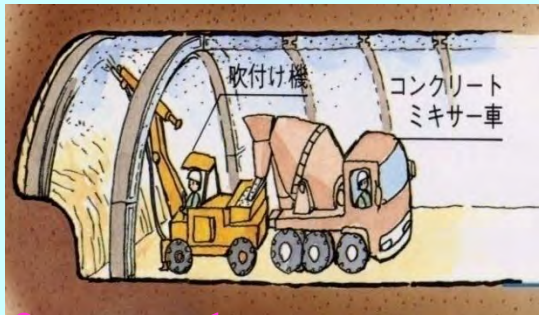

Difference of ground  
Difference of  
construction method

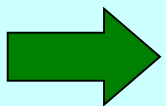

# A schematic drawing of geological structure of Tokyo

Western part of Tokyo

Eastern part of Tokyo

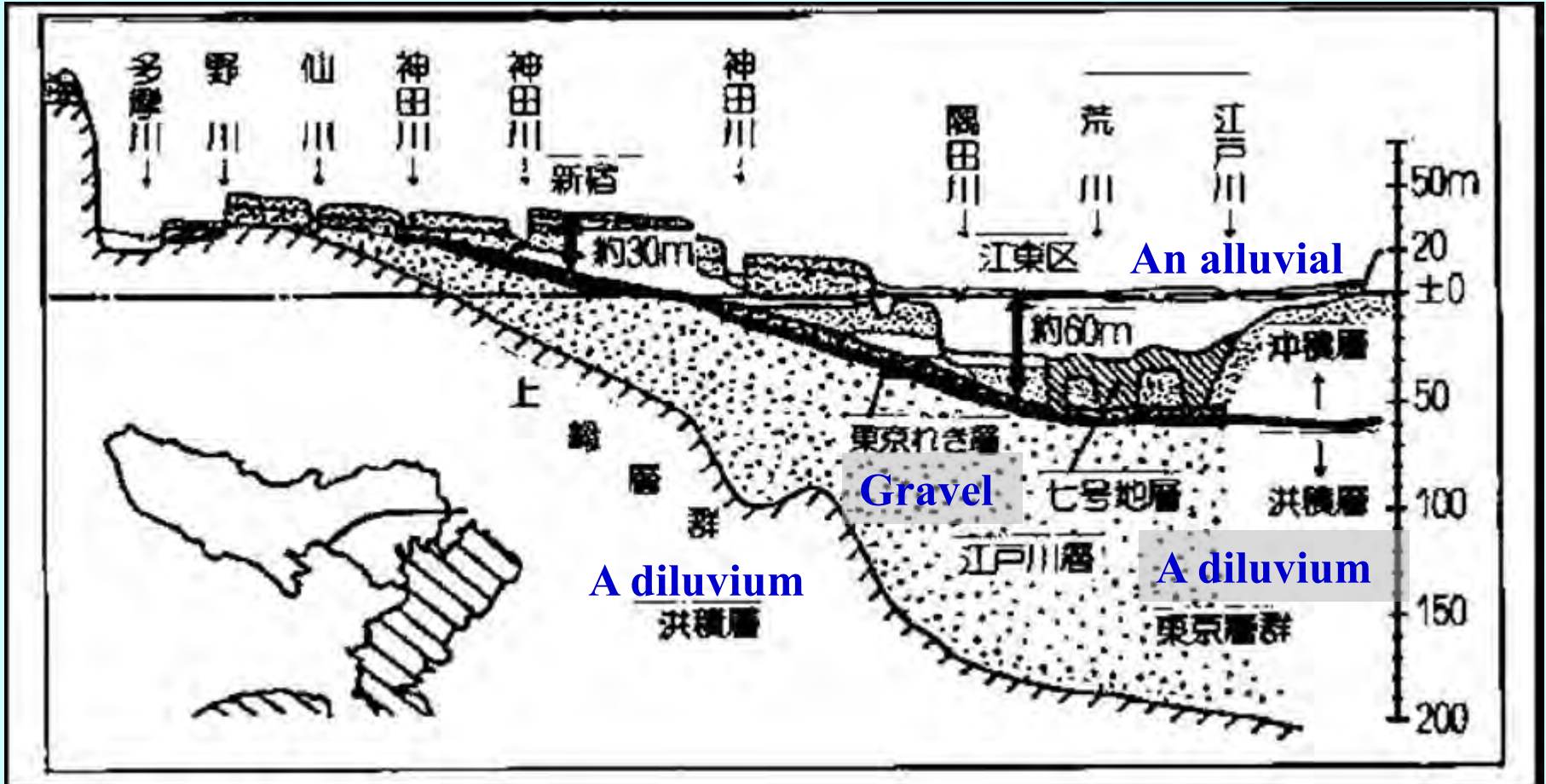

大深度地下開発と地下環境 陶野郁雄 鹿島出版会  
 ジオテクノート 東京の地盤 地盤工学会

より

# Ancient Tokyo bay (130,000 years ago)

Diagonal lines : Land

※ 成田研究グループ 1962

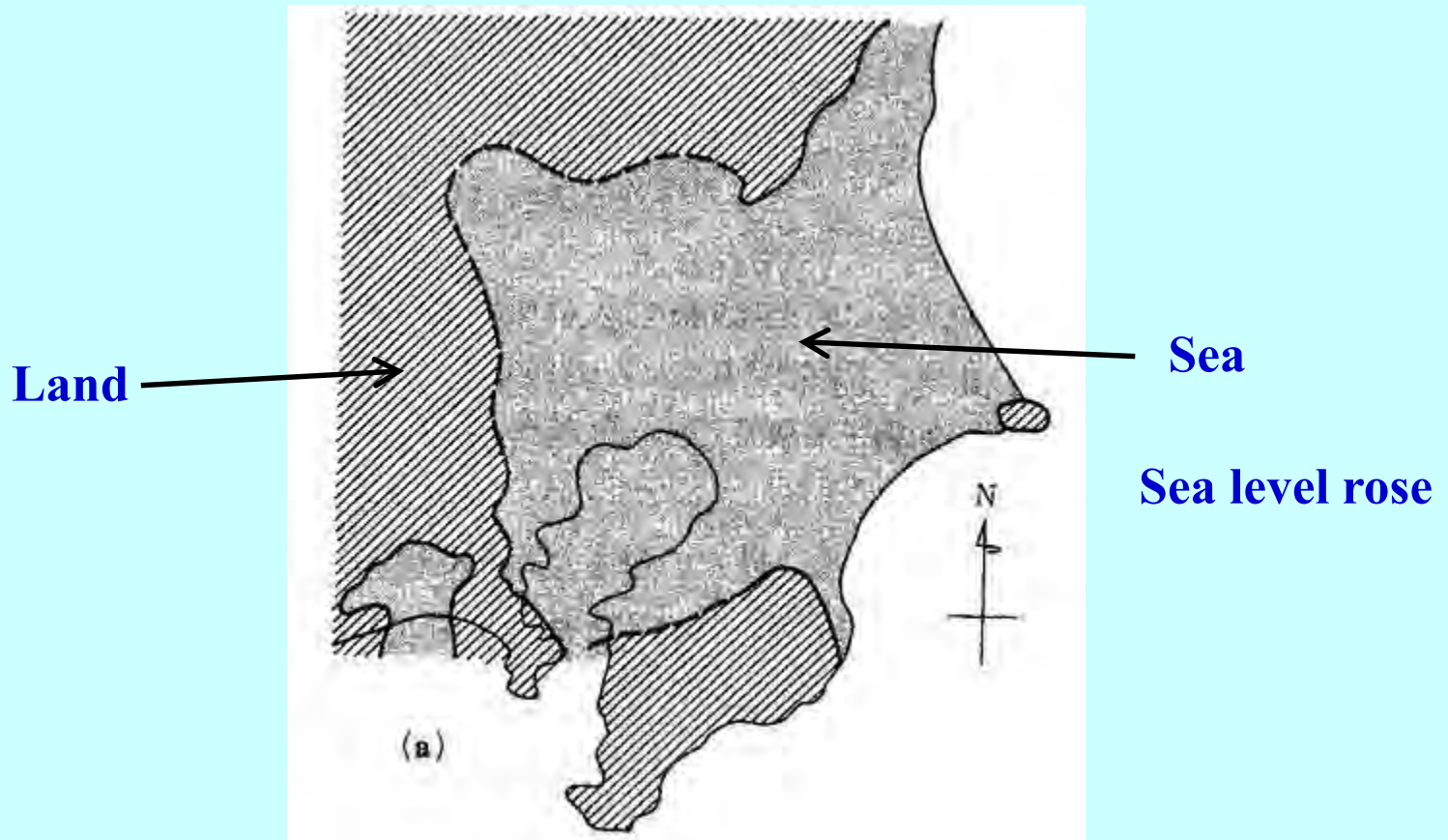

An interglacial period

# Process of forming the alluvial in Tokyo and environs

※ 遠藤 1986

25000-20000 years ago (Deep river)

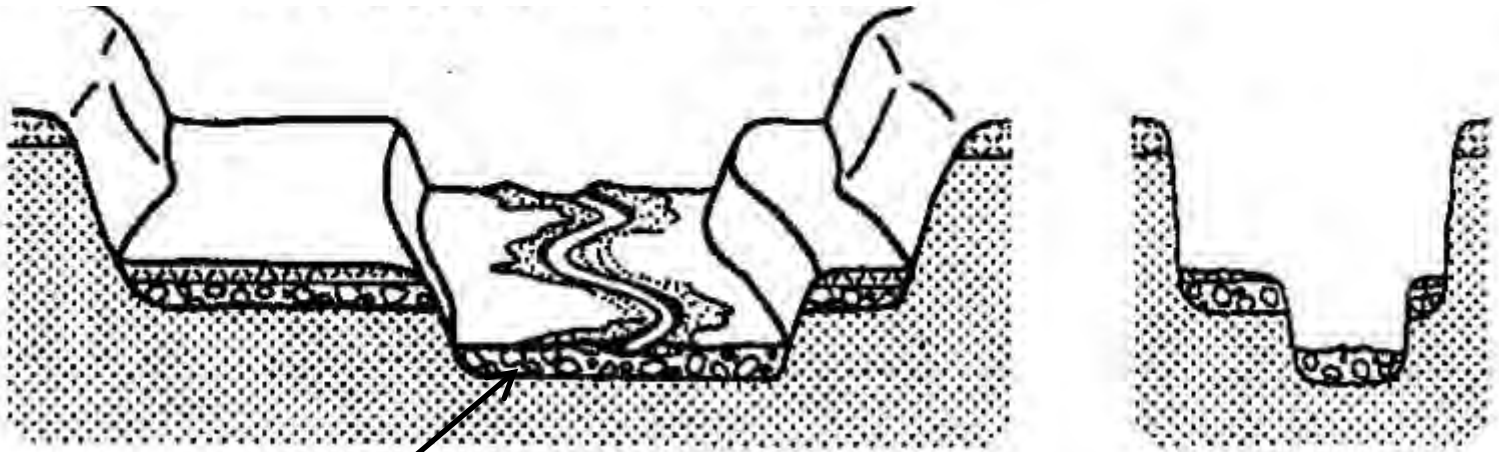

Gravel was piled up.

Sea level came down.

A glacial epoch

# Process of forming the alluvial in Tokyo and environs

Land was encroached by rain

※ 遠藤 1986

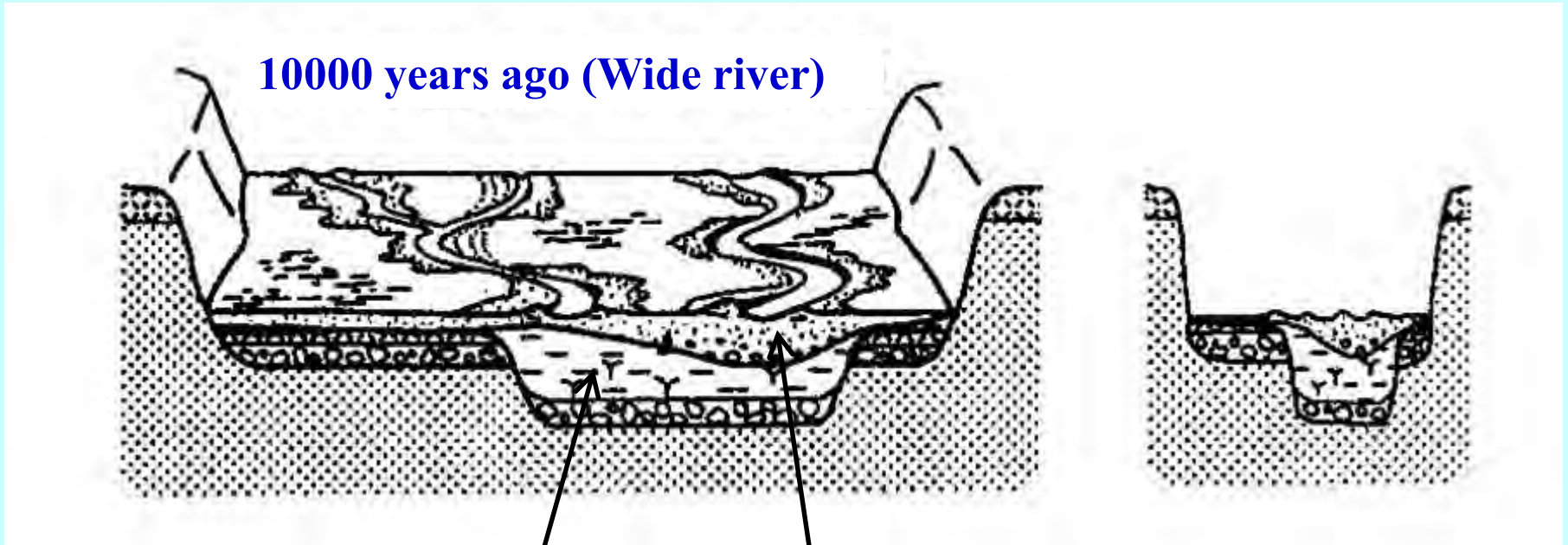

10000 years ago (Wide river)

Clay was deposited.

Sand was piled up.

## Inner part of Tokyo bay (6,000 years ago)

※ 遠藤 他 1983

Diagonal lines : Land

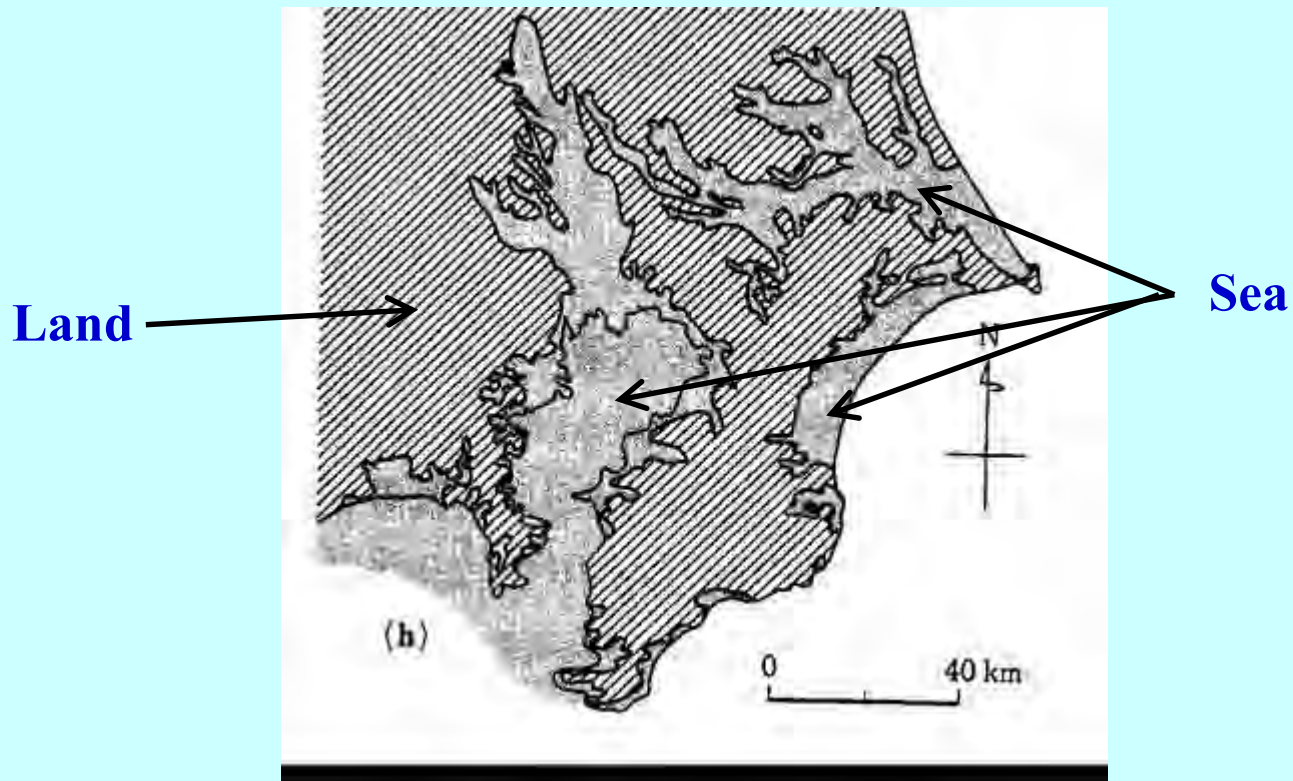

An interglacial period

# Process of forming the alluvial in Tokyo and environs

※ 遠藤 1986

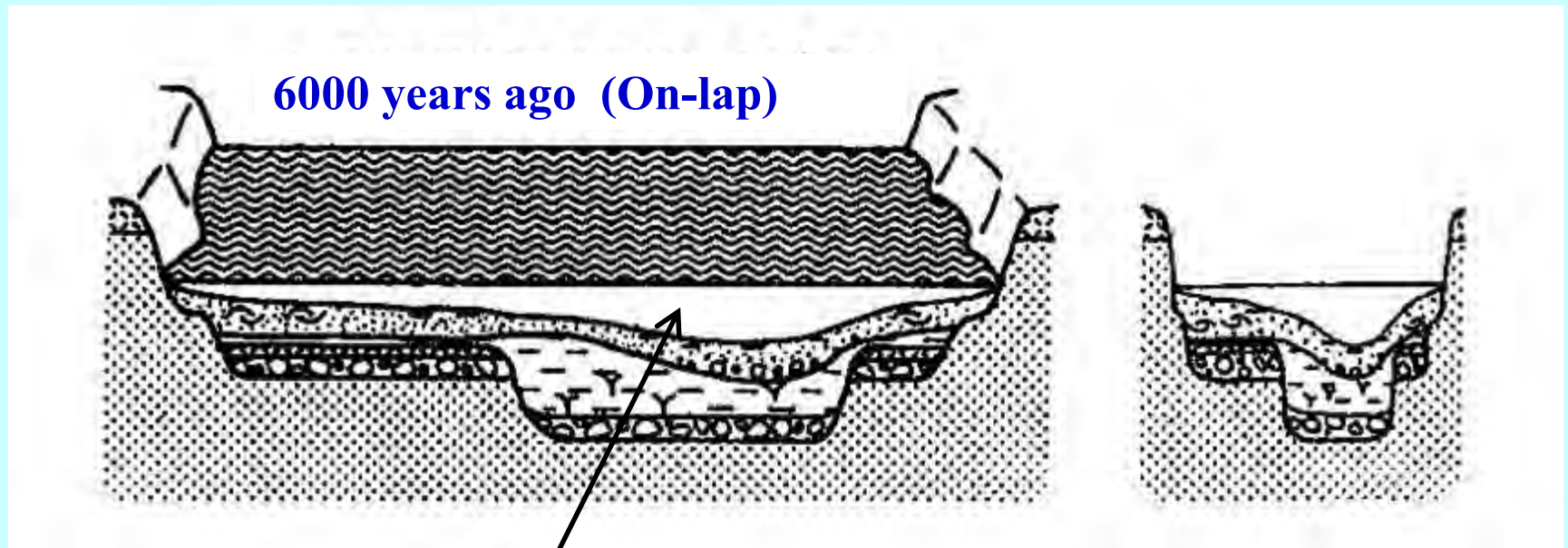

Clay was deposited.

# Process of forming the alluvial in Tokyo and environs

※ 遠藤 1986

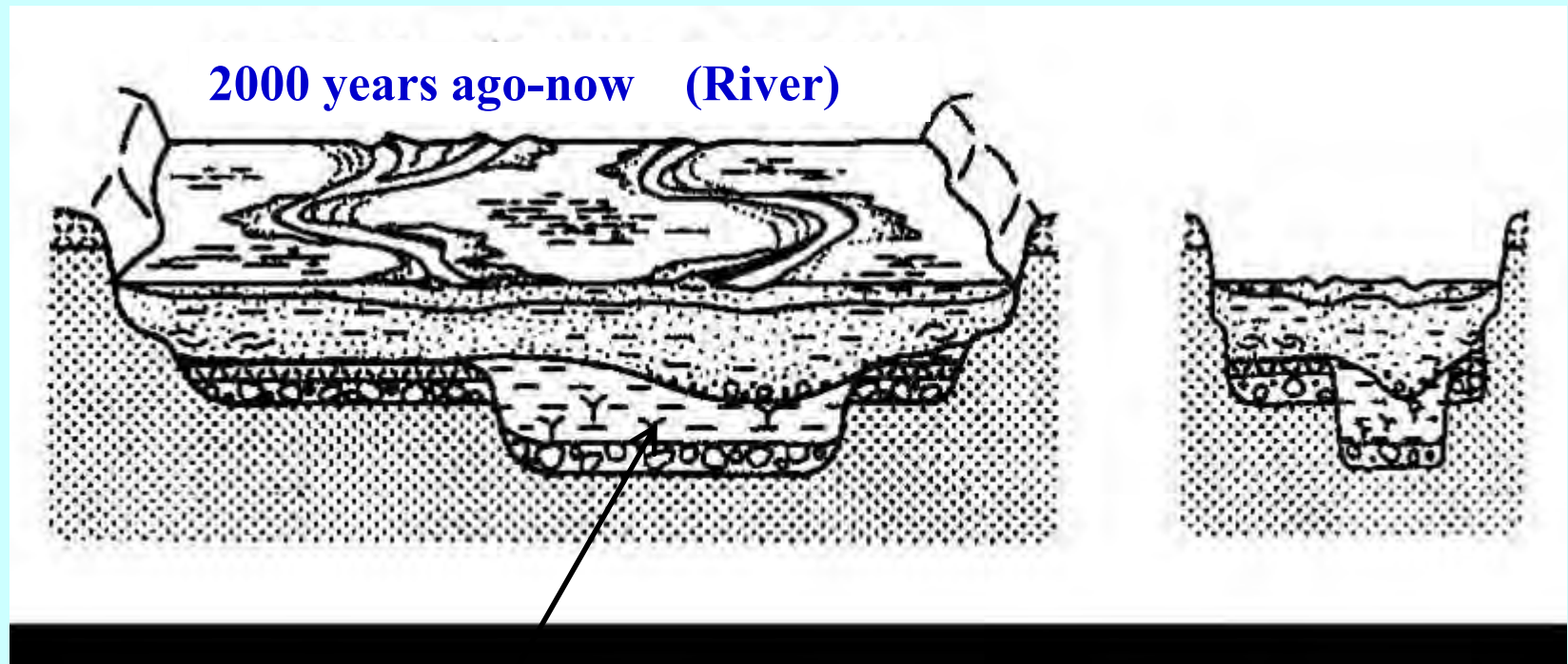

A drowned valley.

# Ground profile of Tokyo bay coastal zone

Western part of Tokyo

Eastern part of Tokyo

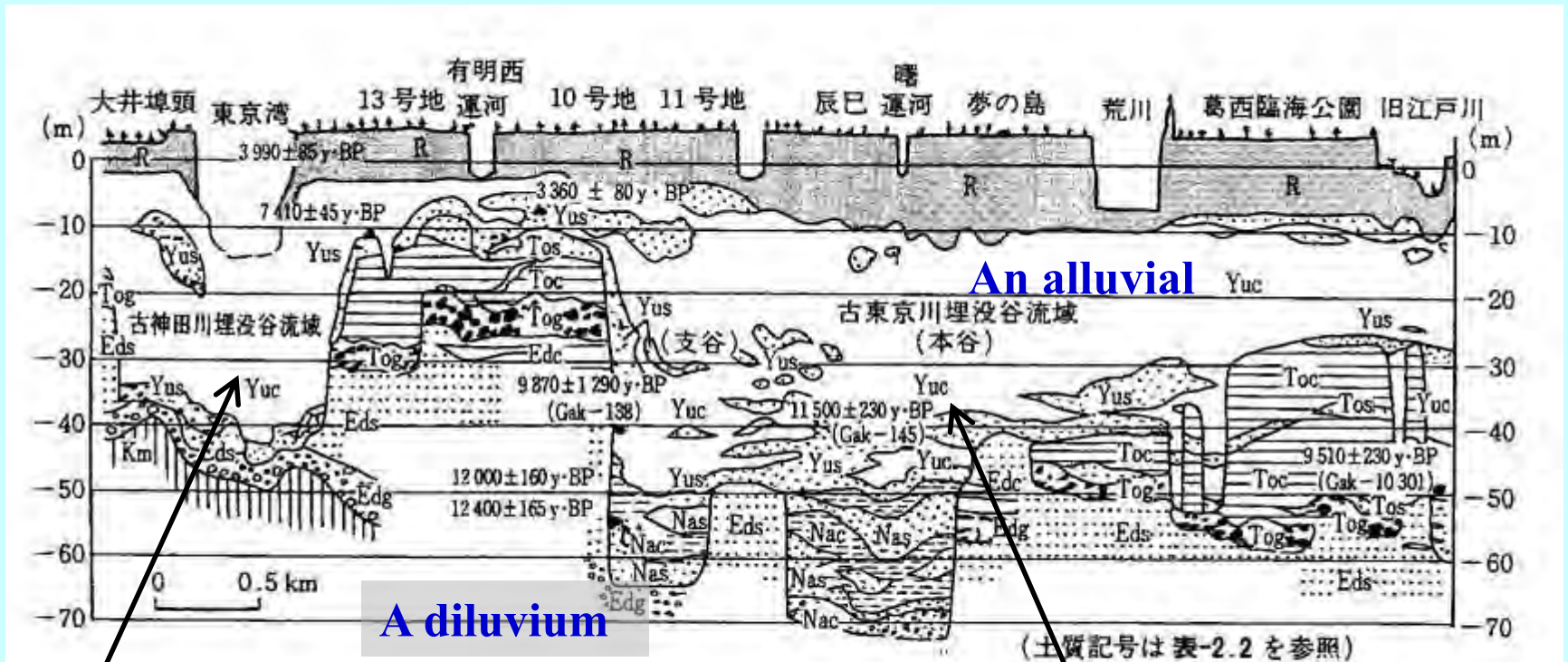

A drowned valley.

A drowned valley.

図-2.9 東京臨海部周辺の地質断面図<sup>12)</sup>

Very complex !

# Contents

- 1. What's a shield tunnel?**
- 2. How to make a shield tunnel?**
- 3. Recent record of shield tunnels in Japan.**
- 4. Design method of a shield tunnel.**
- 5. Examples of shield tunnel projects.**
- 6. SENS method**

# 1. What's a shield tunnel?

# Shield Tunnel

Shield machine    Shield jack    Segment

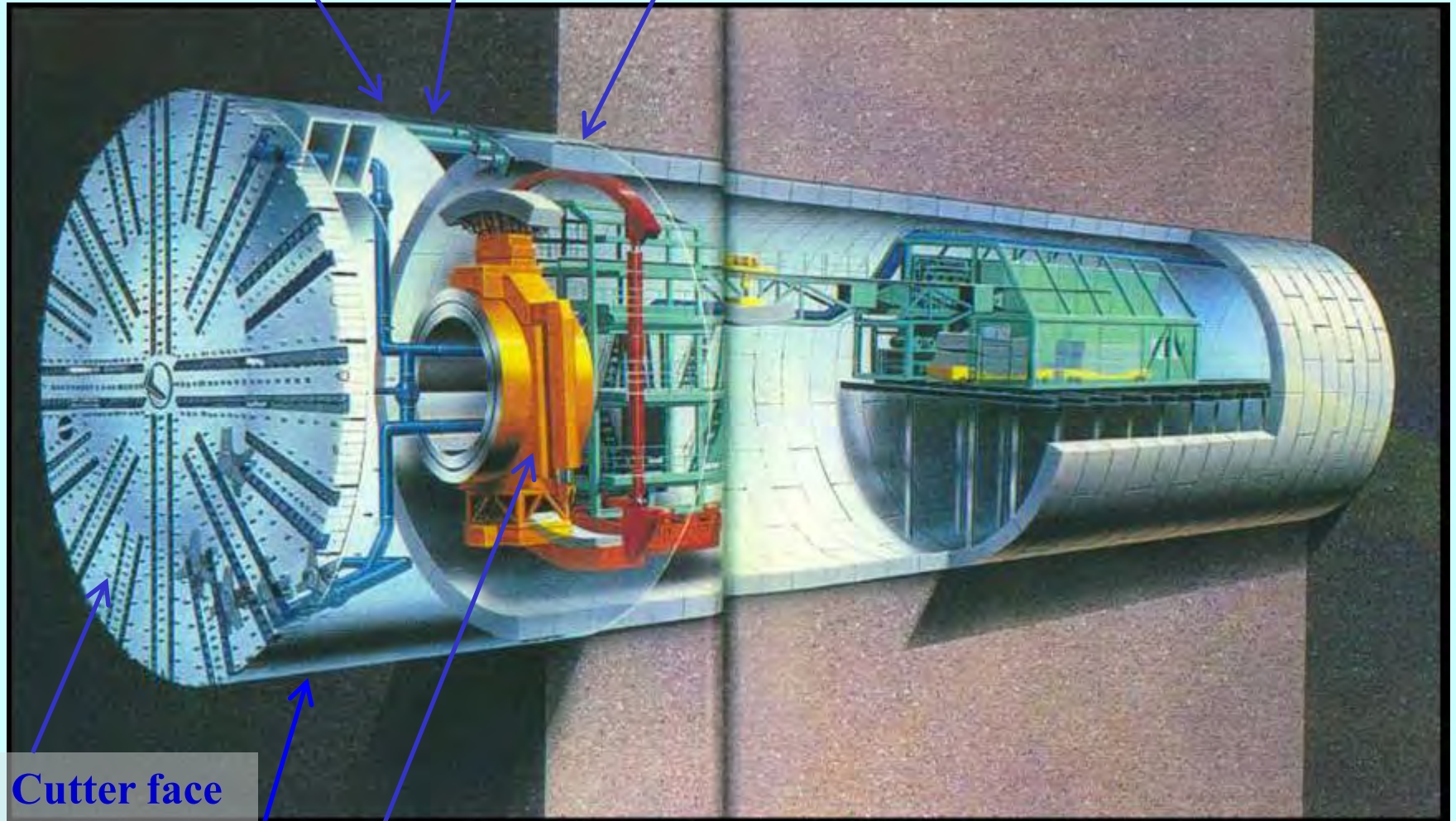

Cutter face

Skin plate

Elector

新しいシールドトンネルより

# Segment

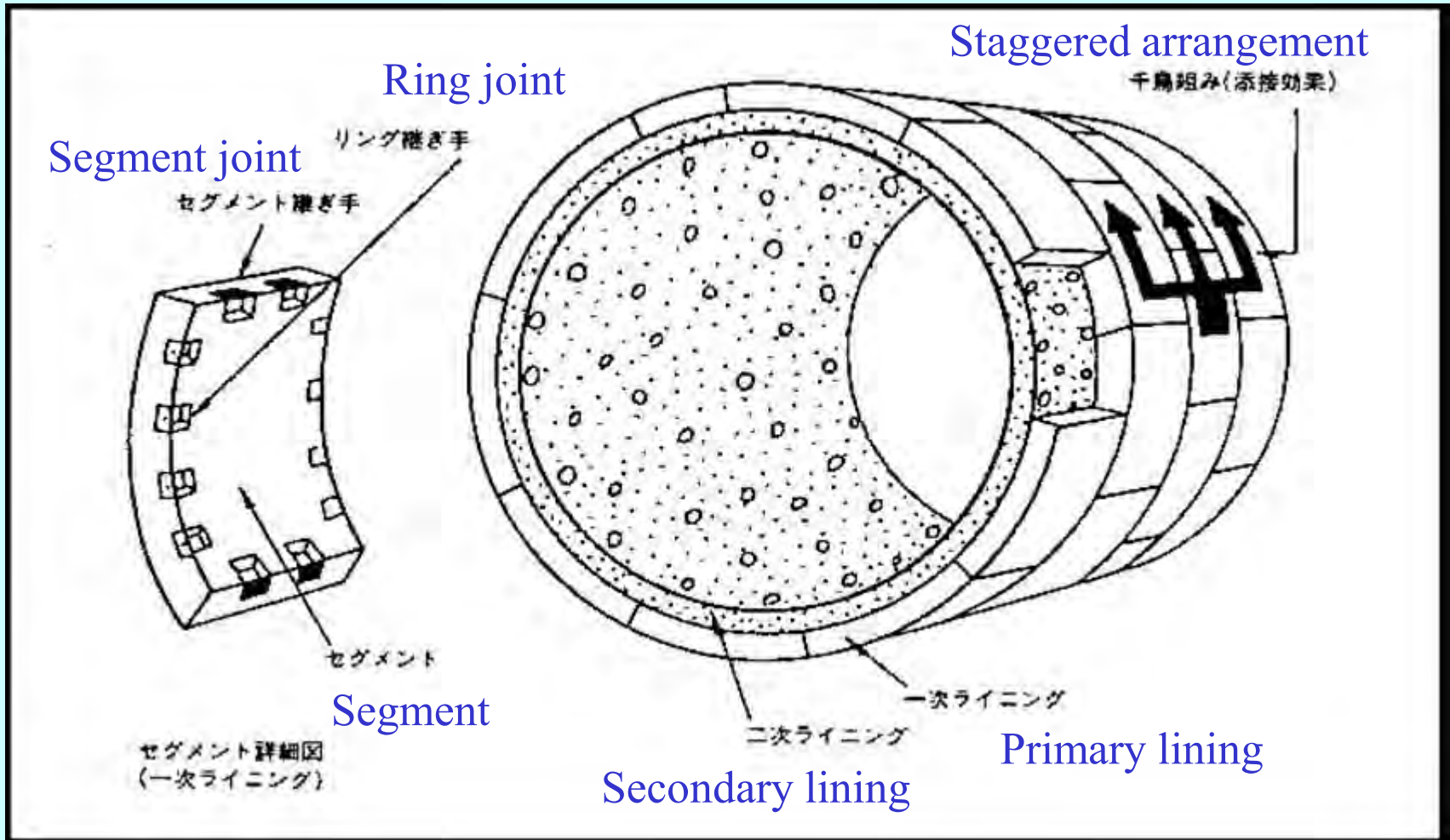

# Reinforced concrete segment

Box type segment



Flat type segment

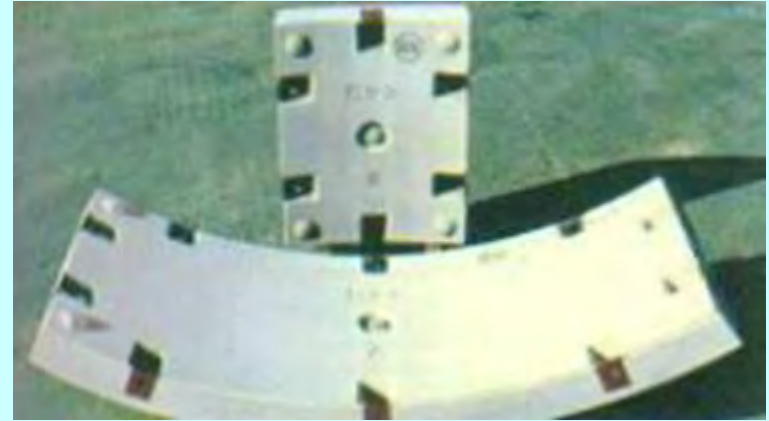

# Ductile cast iron segment



# Special segments

## Honeycomb segment

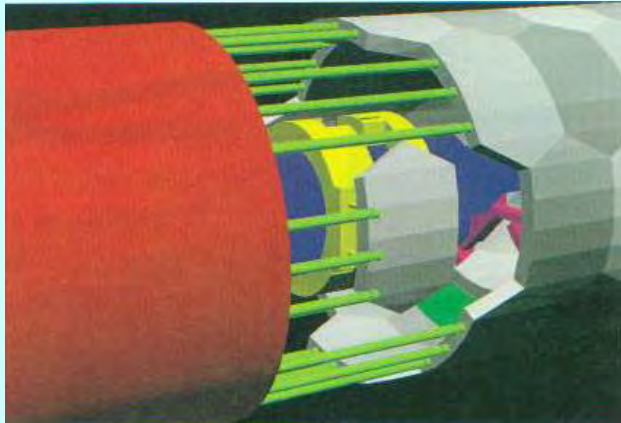

# Composite segment

## New Mechanically- jointed Segment



## Pin-tenon segment

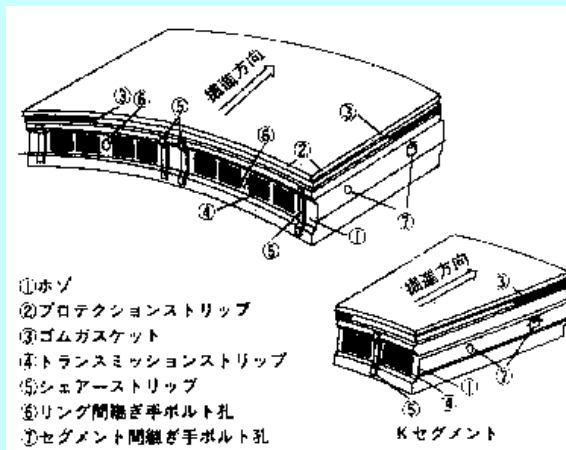

# Contents

**1. What's a shield tunnel?**

**2. How to make a shield tunnel?**



**3. Recent record of shield tunnels in Japan.**

**4. Design method of a shield tunnel.**

**5. Examples of shield tunnel projects.**

**6. SENS method**

# COMPARISON-1.Outline of construction methods

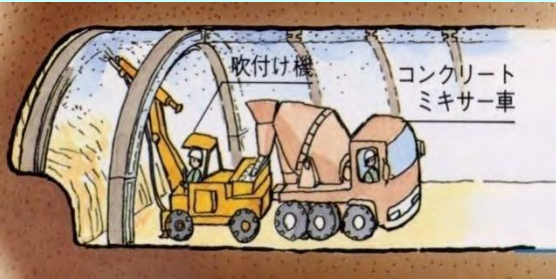
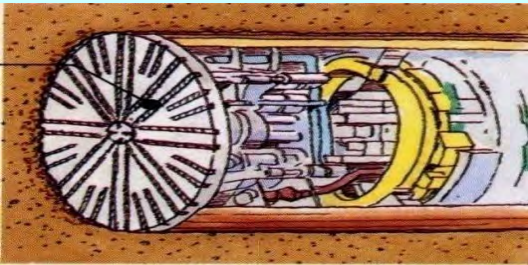
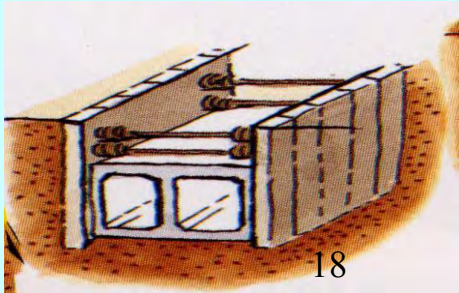
NATM	Shield	Cut & cover
<ul style="list-style-type: none"> <li>▪ <u>Shot Crete</u>, <u>Steel support</u>, <u>Rock Bolt</u></li> <li>▪ Making full use of the natural support function of the surrounding ground</li> <li>▪ Prerequisite condition is that face remains standing when excavated</li> </ul>	<ul style="list-style-type: none"> <li>▪ <u>Segmental Lining.</u></li> <li>▪ The skin plate of the shield machine, outer backfill layer of the shield and the segmental support the wall of the tunnel.</li> <li>▪ Closed-type shield stabilizes the face using earth or slurry to counter earth or hydraulic pressure.</li> </ul>	<ul style="list-style-type: none"> <li>▪ Earth-retaining wall, Main body</li> <li>▪ The ground excavated from the surface to build the tunnel at the desired depth. Then the excavated earth is brought back to restore the surface.</li> </ul>
 <p>吹付け機 コンクリート ミキサー車</p>		

## COMPARISON-2.Countermeasure for underground water

NATM	Shield	Cut & cover
<ul style="list-style-type: none"> <li>When there is water inflow that affects the self-support of the face or stability of the ground during excavation, water sealing method such as by deep well, well point, or drainage tunnel is necessary.</li> </ul>	<ul style="list-style-type: none"> <li>Usually, closed type shield does not require countermeasures, but the open type does.</li> </ul>	<ul style="list-style-type: none"> <li>Countermeasures such as deeper penetration of earth retaining wall, groundwater reducing method, soil improvement etc. are usually necessary to overcome boiling or heaving.</li> </ul>

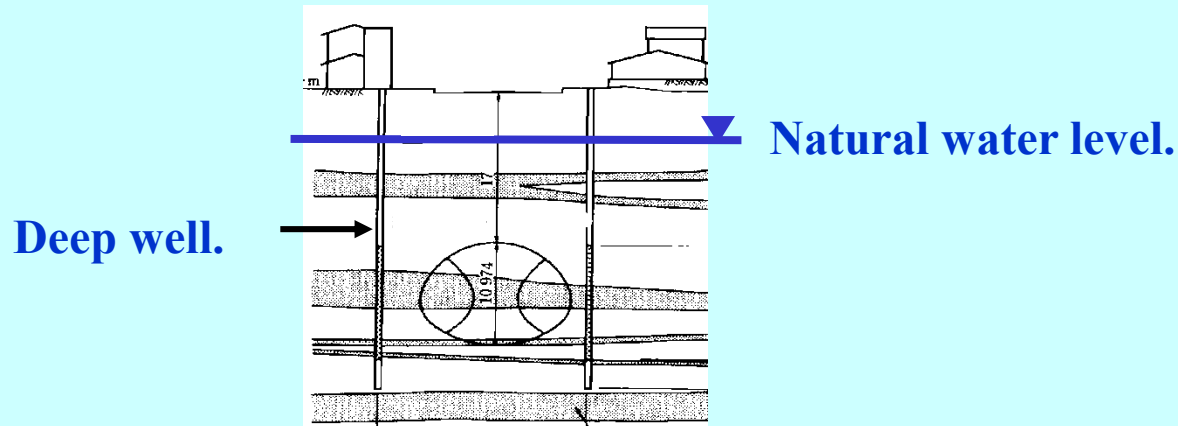

# Face collapse

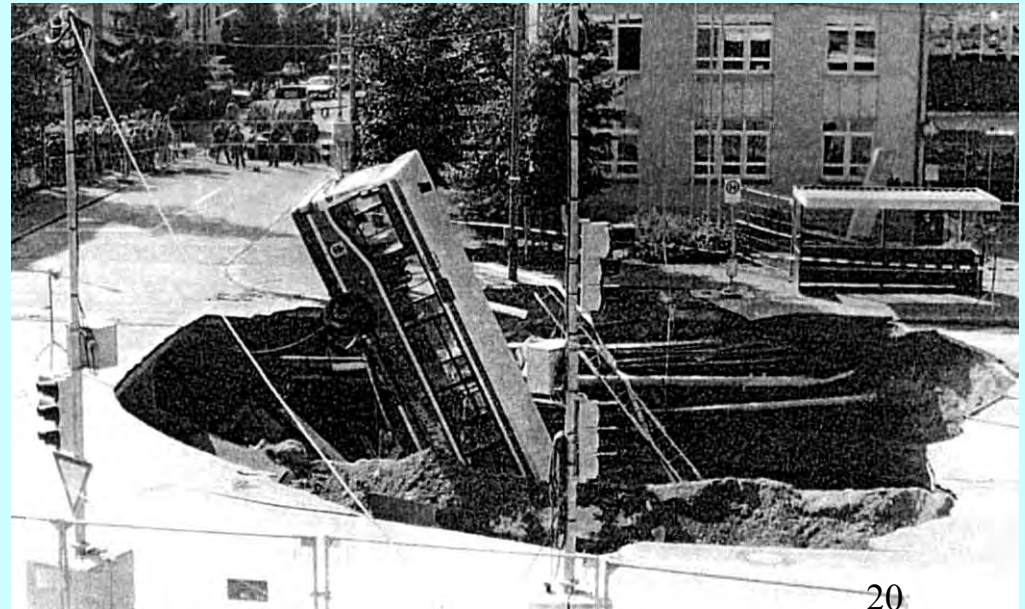

# Open Type Shield

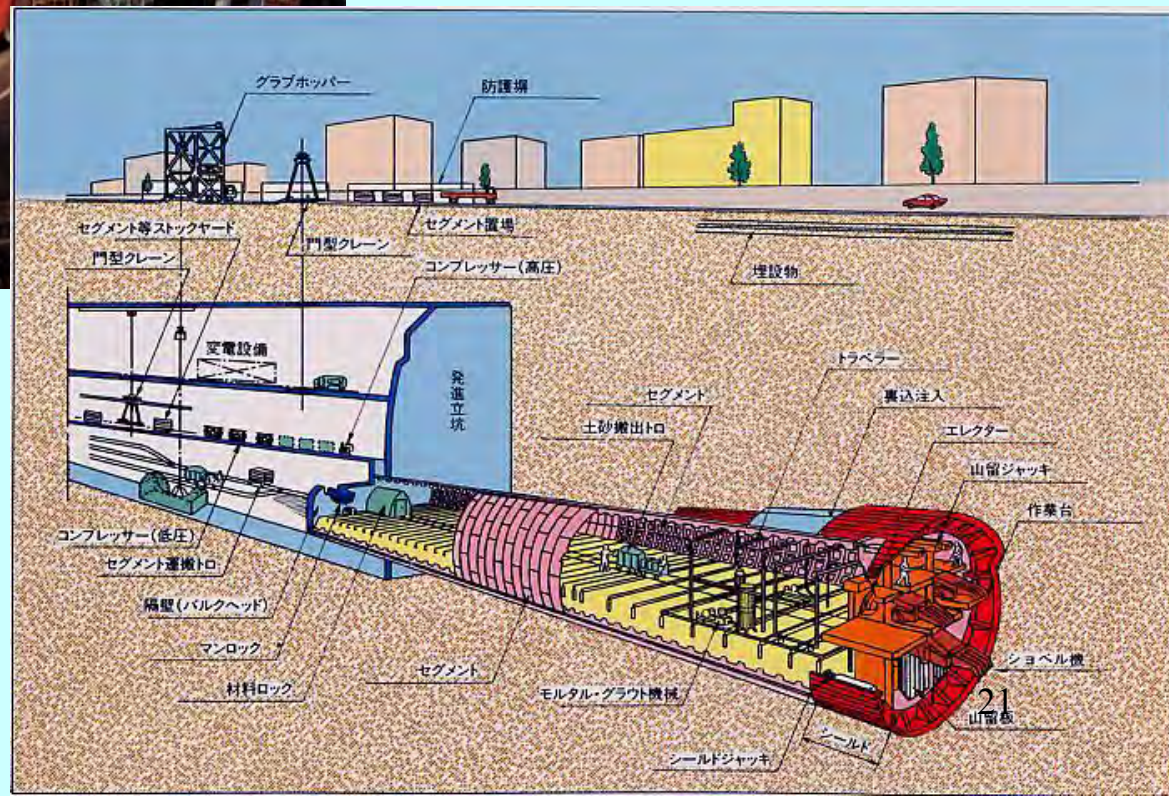
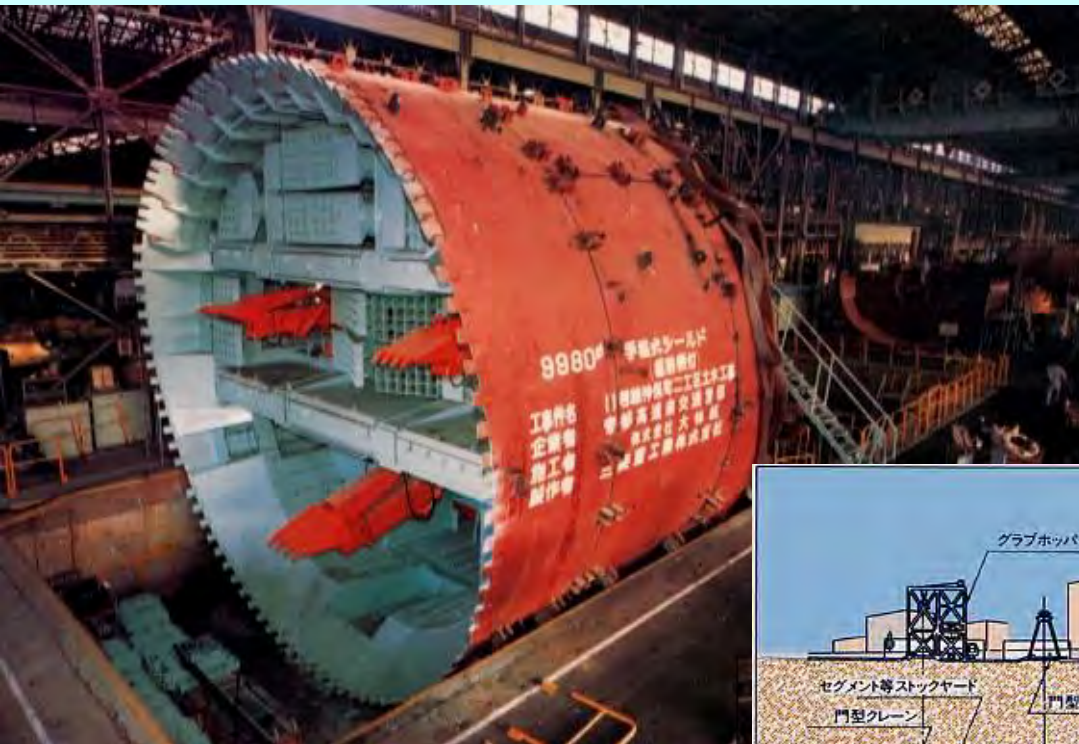

# Slurry shield

# (Closed Type Shield)



## 泥水式シールド工法の原理

Principle of "Slurry Shield Method"

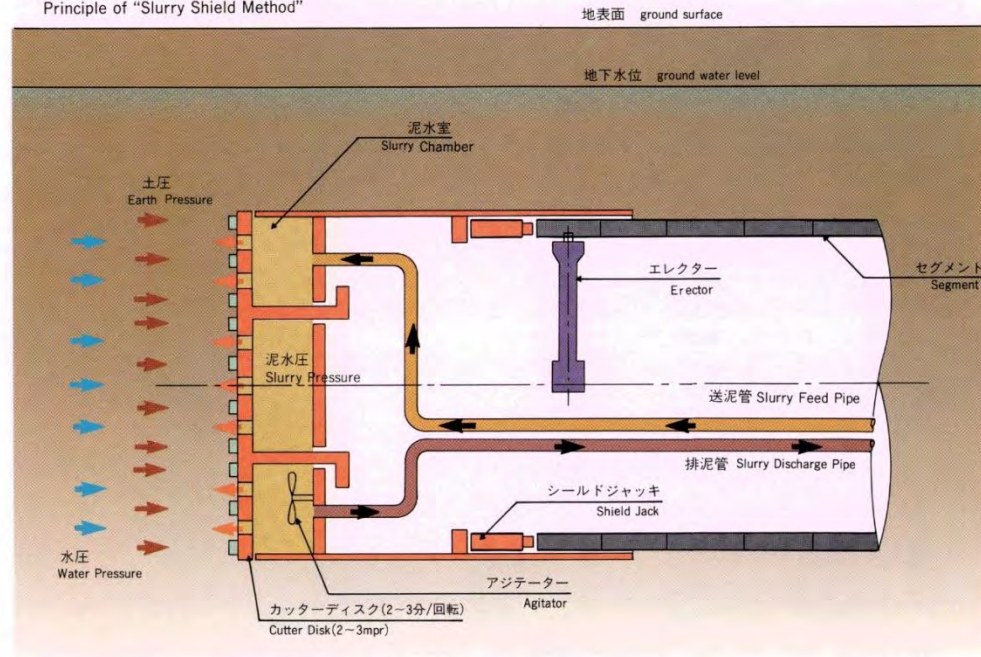

# Earth Pressure Balanced shield (Closed Type Shield)

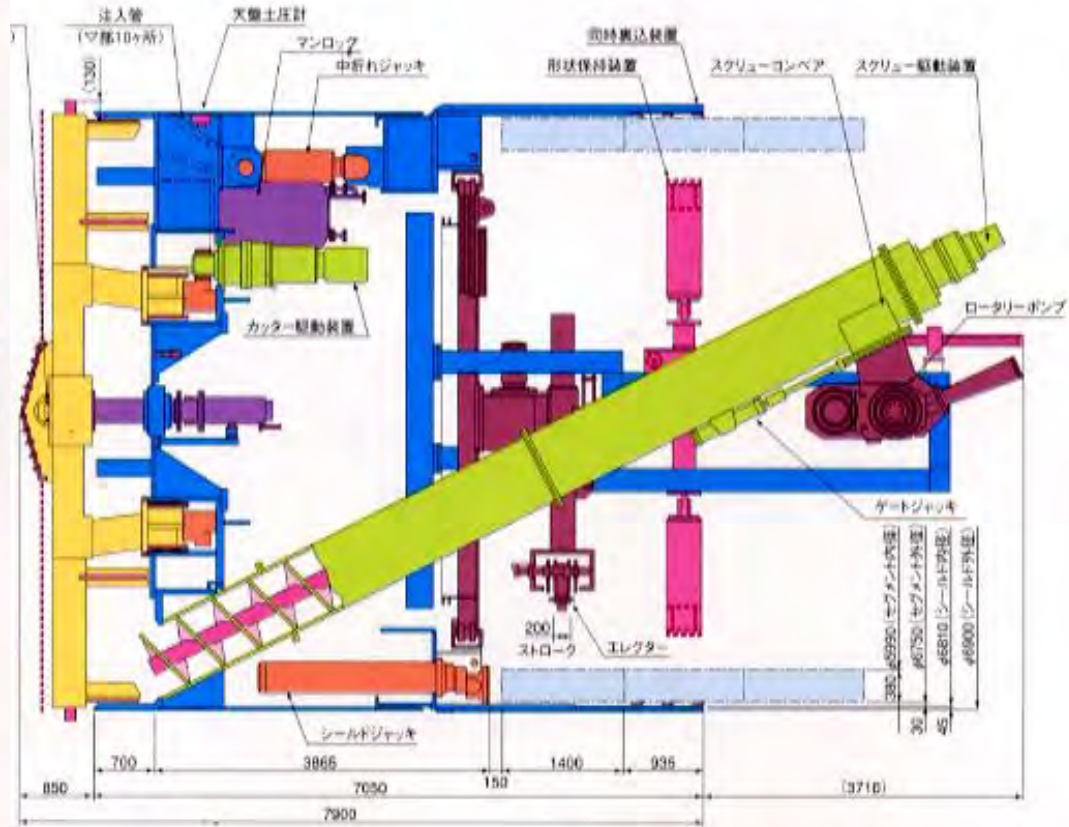

# Case Study of Railway Shield Tunnel

- In Japan, a shield tunneling method is applied widely in an urban region with soft ground from 1960s.

Open type shield

settlement of the ground: large



Open type shield machine  
(Manual excavation type)

Closed type shield

settlement of the ground: small

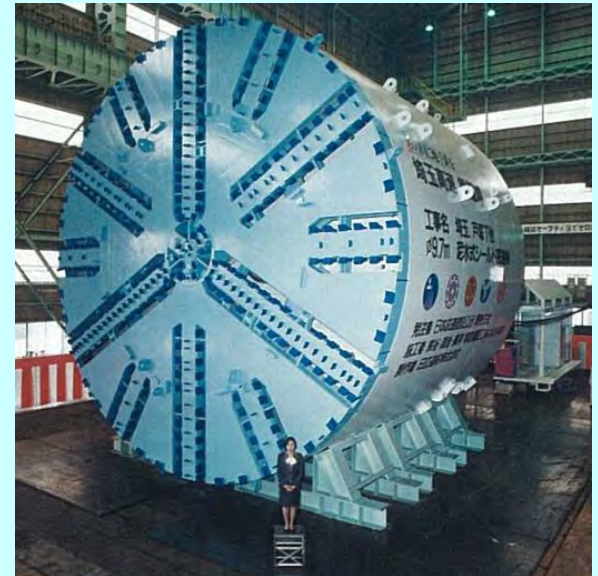

Closed type shield machine  
(Slurry type)

# Selected Shield Type

## Applied shield types of each decade

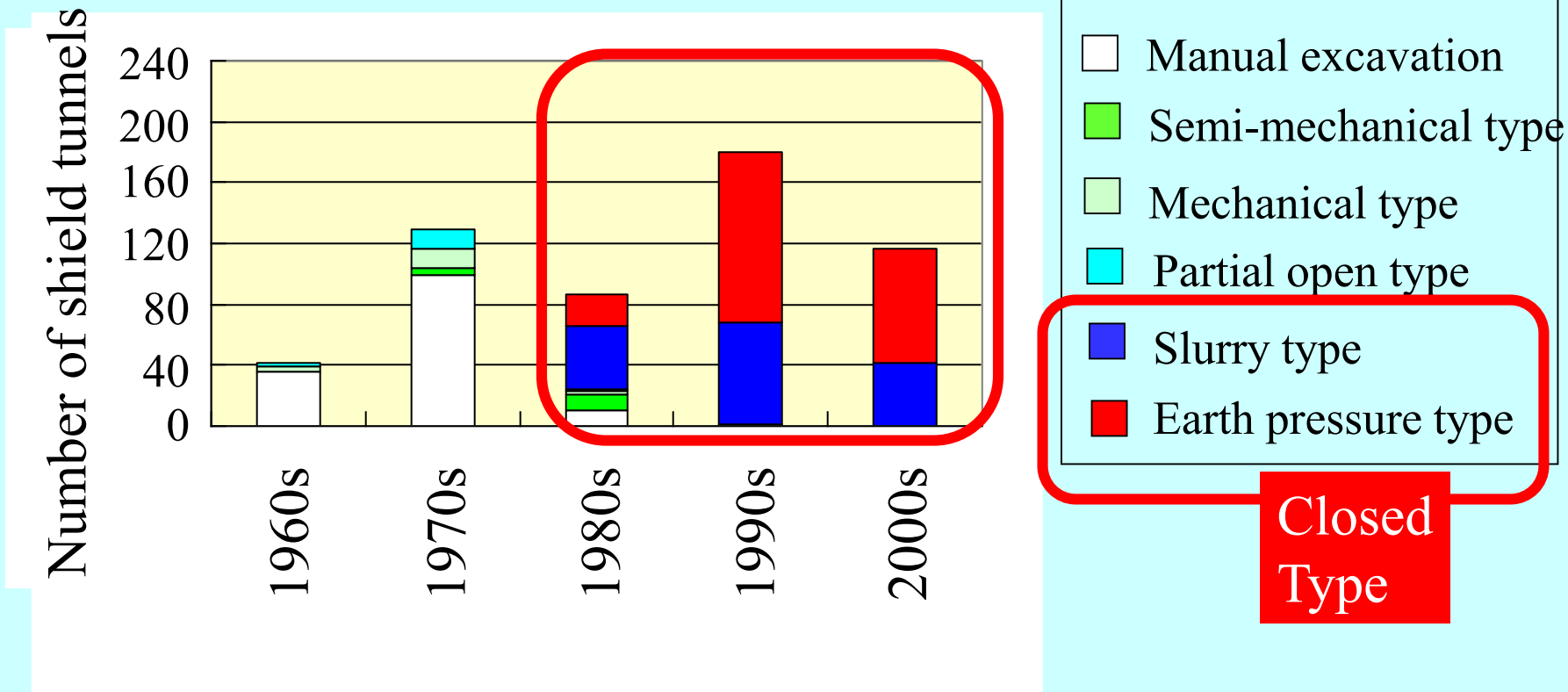

**Before 1970s:** Manual excavation type is mainly applied.  
(Mechanical and Partial open types are also applied.)

**After 1980s:** Closed type is mainly applied.  
(1980s: Slurry type, 1990s: Earth pressure type)<sup>25</sup>

# Simultaneous Back-fill Grouting

Ground

同時裏込め注入

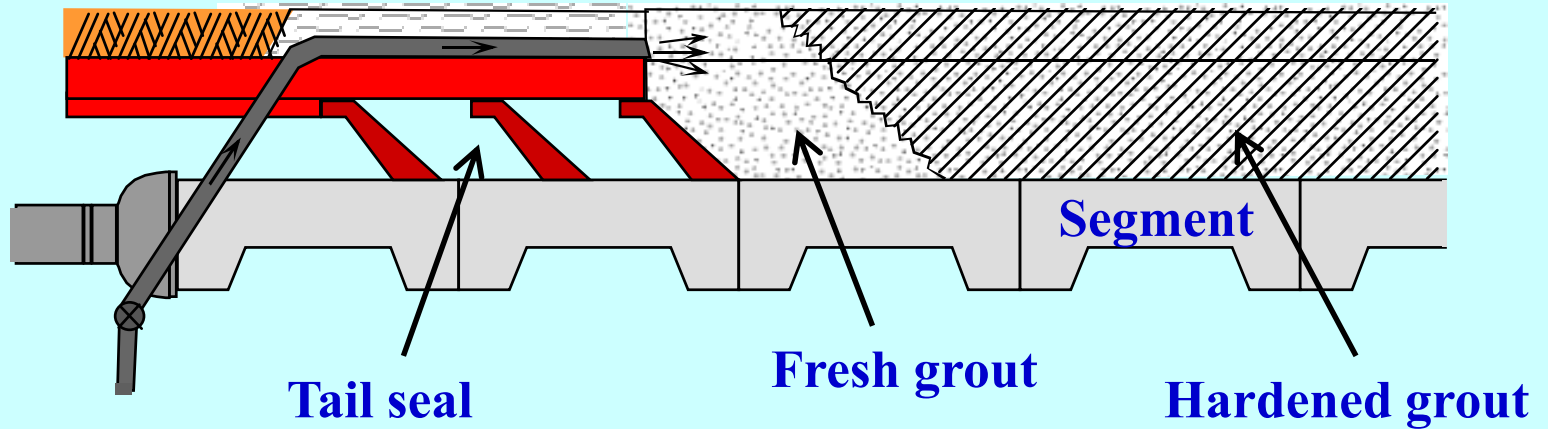

# Immediate Back-fill Grouting

即時裏込め注入

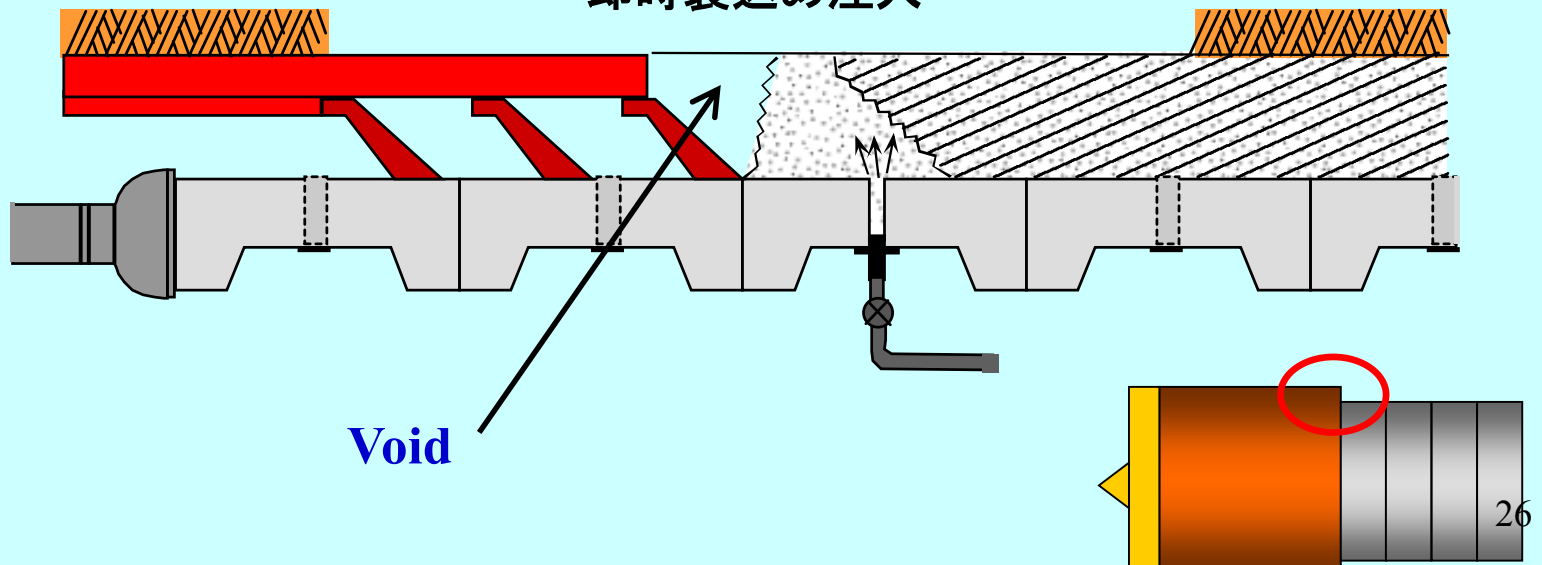

# Tail seal composed of wire brushes and high-viscose grease

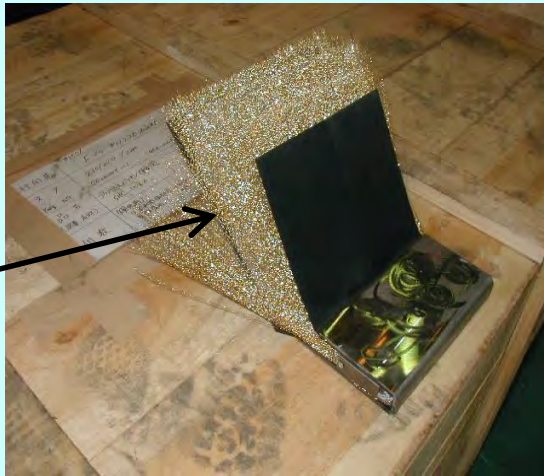

Wire brush



Wire brushes

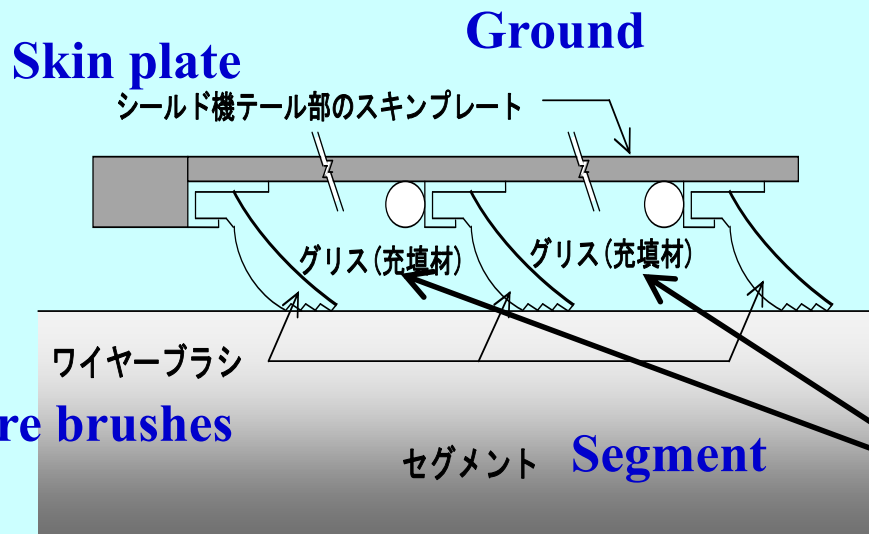

High-viscose grease

# Back-fill grouting



0%      20%      40%      60%      80%      100%

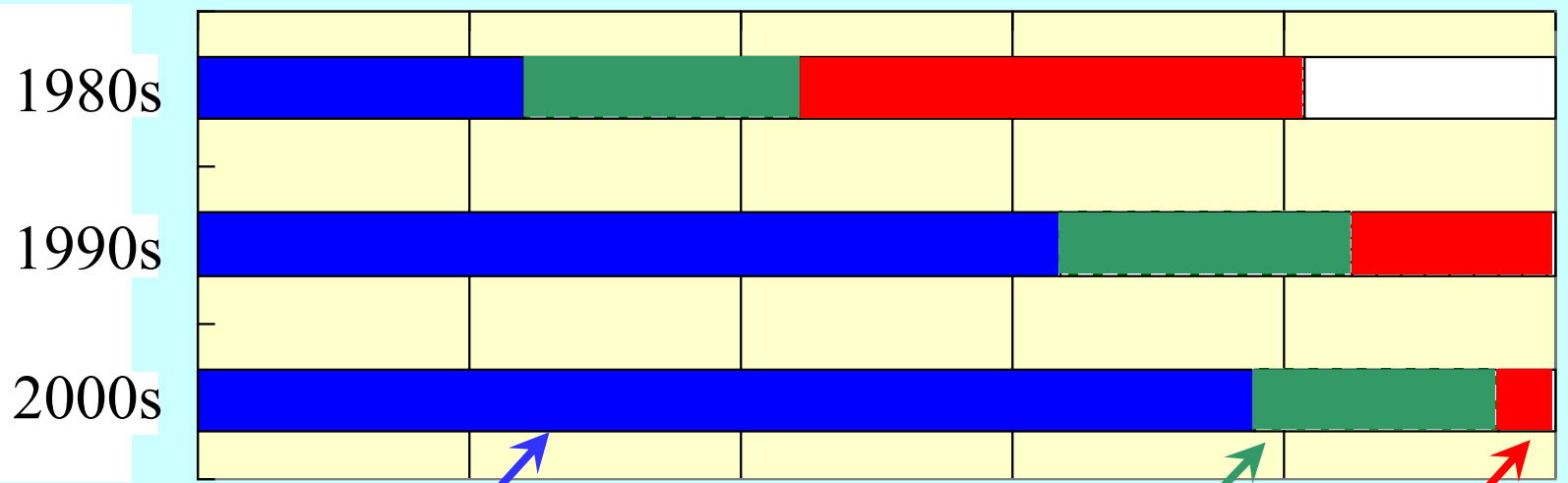

Simultaneous grouting

Semi simultaneous grouting

Immediate grouting

Simultaneous grouting increases in number.

1980s: Simultaneous grouting = 25%.

2000s: Simultaneous grouting = Near 80%

シールド工事の順序

Starting Shaft

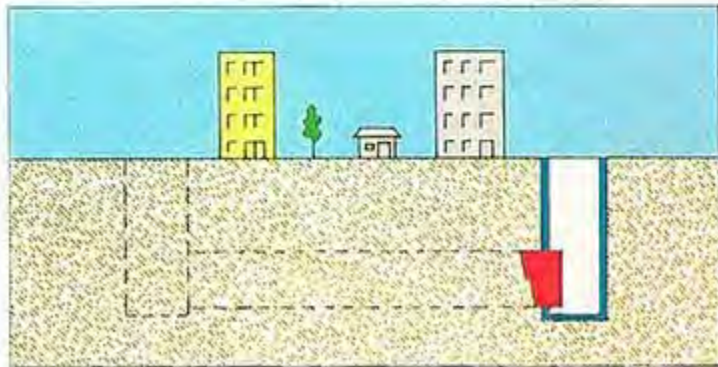
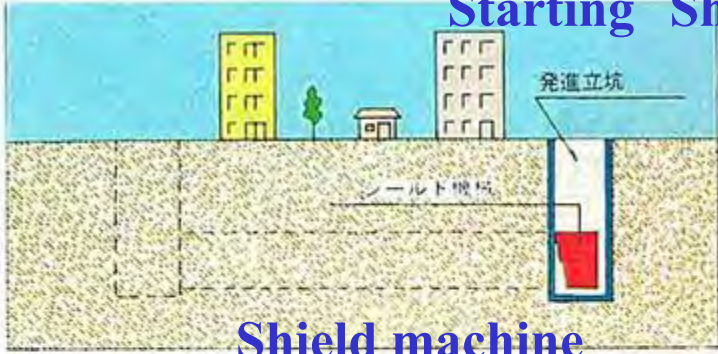

Arriving Shaft



## 2. How to make a shield tunnel?

Procedure of shield tunnel construction

Taking a machine apart

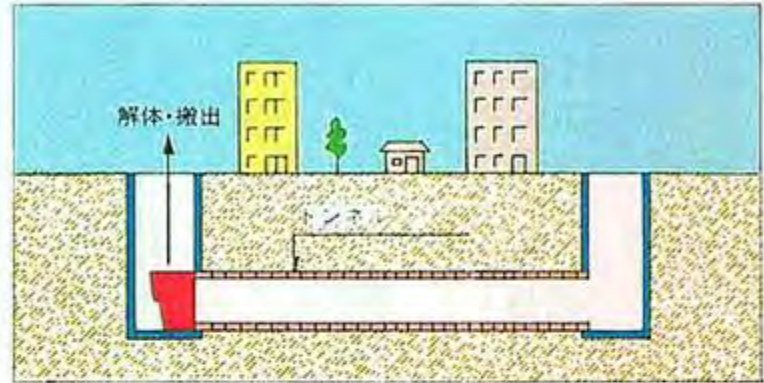

Remove

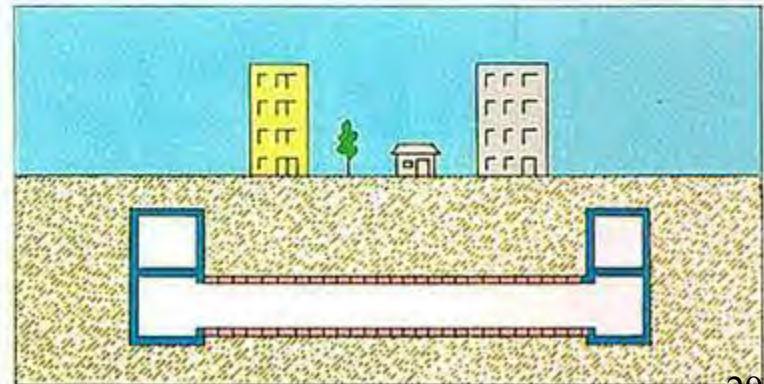



## Moving facilities

Elector

Muck Removal Facilities

Face  
(Nanboku Line)  
(Saitamakousou)

*Like a factory!*

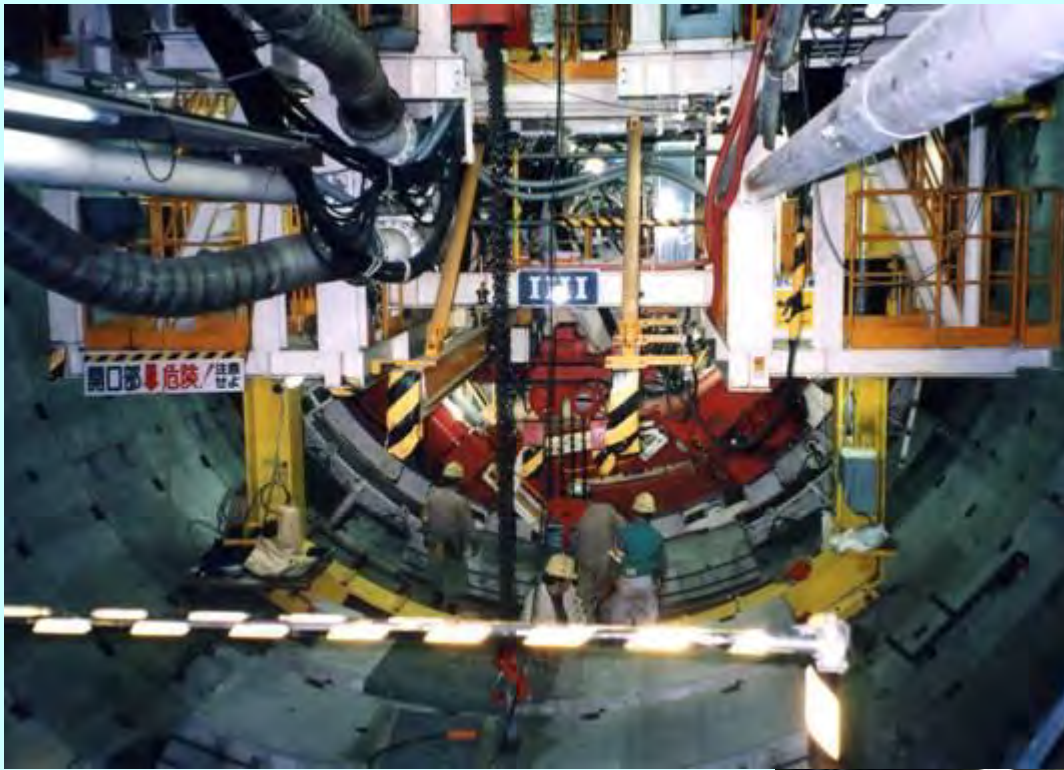



## Inside of a tunnel

**Material Handling Facilities**

**Lightning System**

**Water Supply Facilities**

**Ventilation Facilities**

**Grouting material Supply Facilities**

**Communication Facilities**

## Facilities

**Electric Power Supply Facilities**

**Material stock Facilities**

**Grouting material stock Facilities**





**Tunnel entrance**



**00:00~6:10**  
**12:40~17:20**  
**19:14~24:10**

**Stock Yard**



# Shield tunnel

An example for Railway tunnel  
Single track tunnel,  
Kyoto City Subway

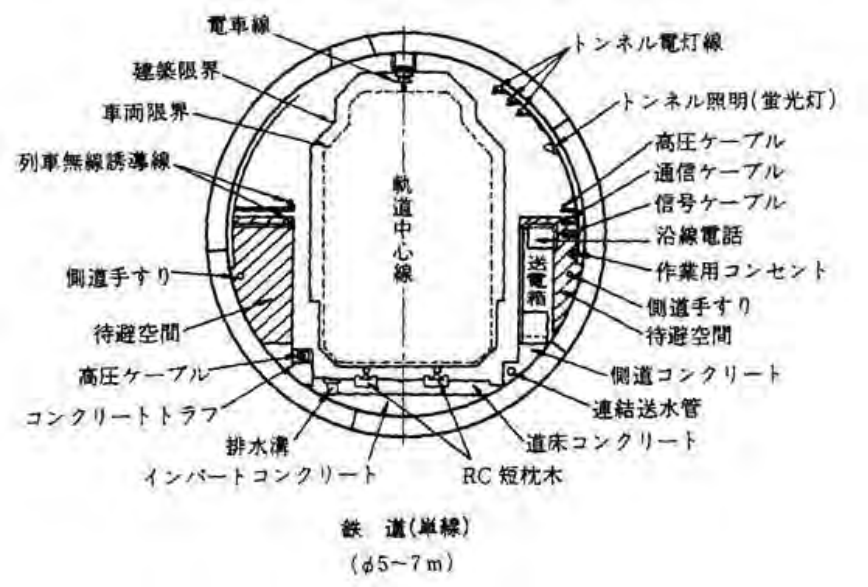

An example for Railway tunnel  
Single track tunnel

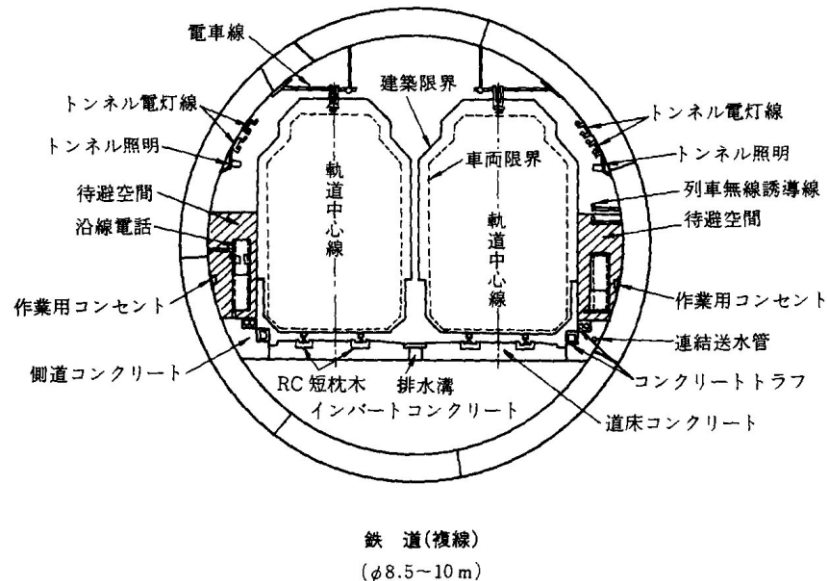

An example for Railway tunnel  
Double track tunnel



東大路T 西行 (終点方を望む)

# Typical cross sections of a sewerage tunnel and a water supply tunnel

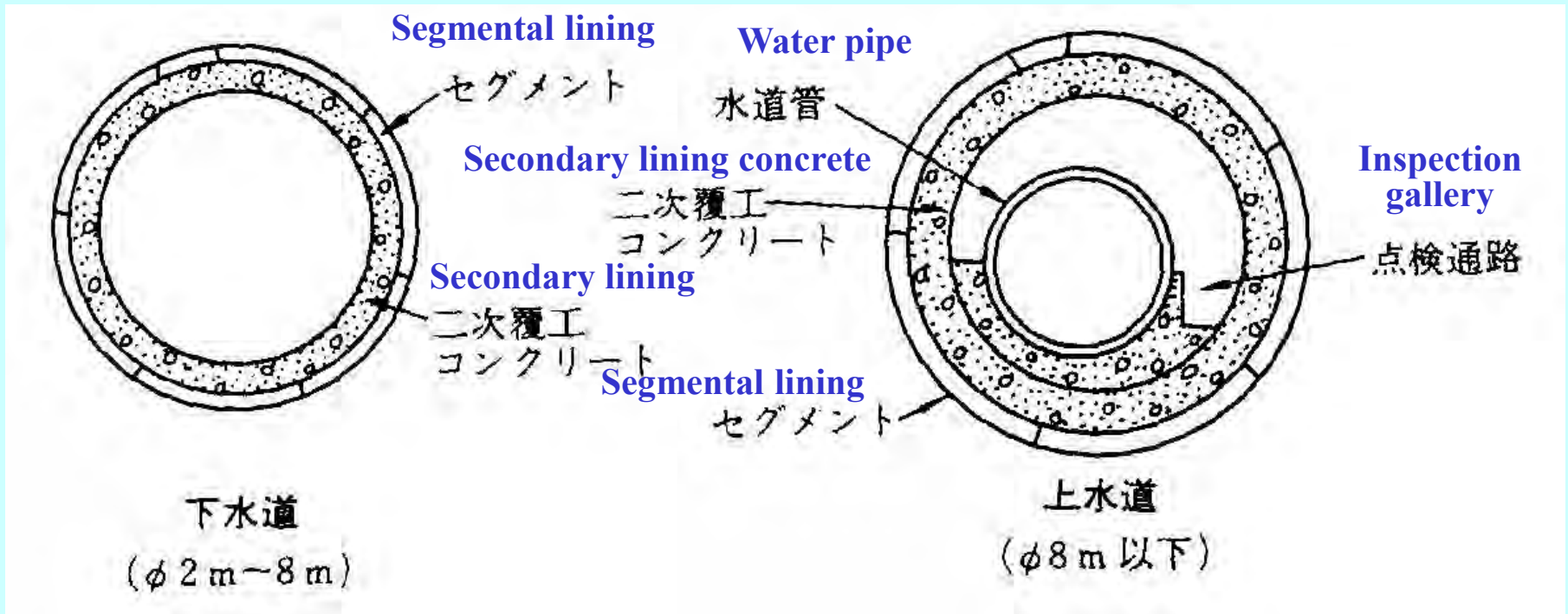

An example for a sewerage tunnel

An example for a water supply tunnel

# Typical cross sections of a power cable tunnel and a telecommunicational tunnel

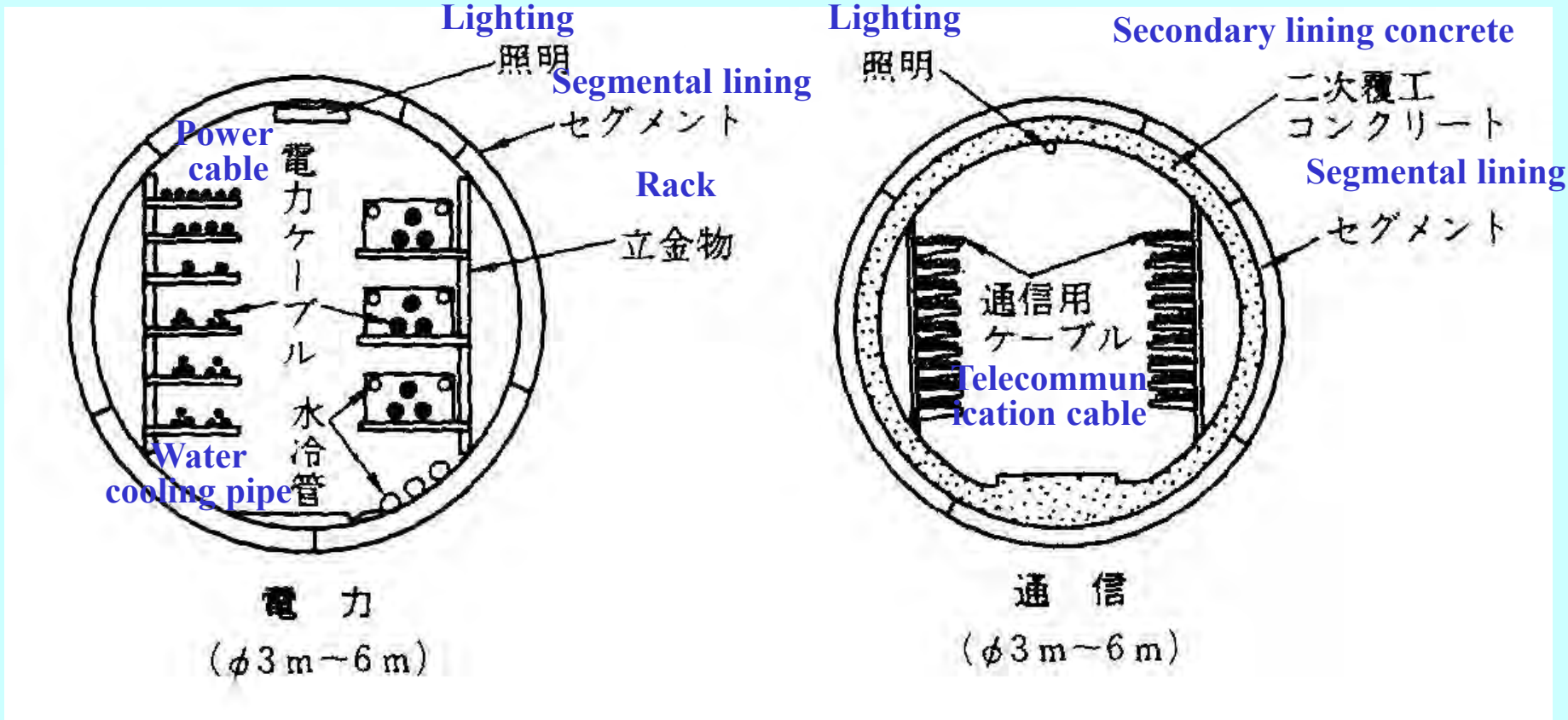

An example for a power cable tunnel

An example for a telecommunicational tunnel

# Typical cross sections of a multiple use tunnel

An example of Kansai electric company

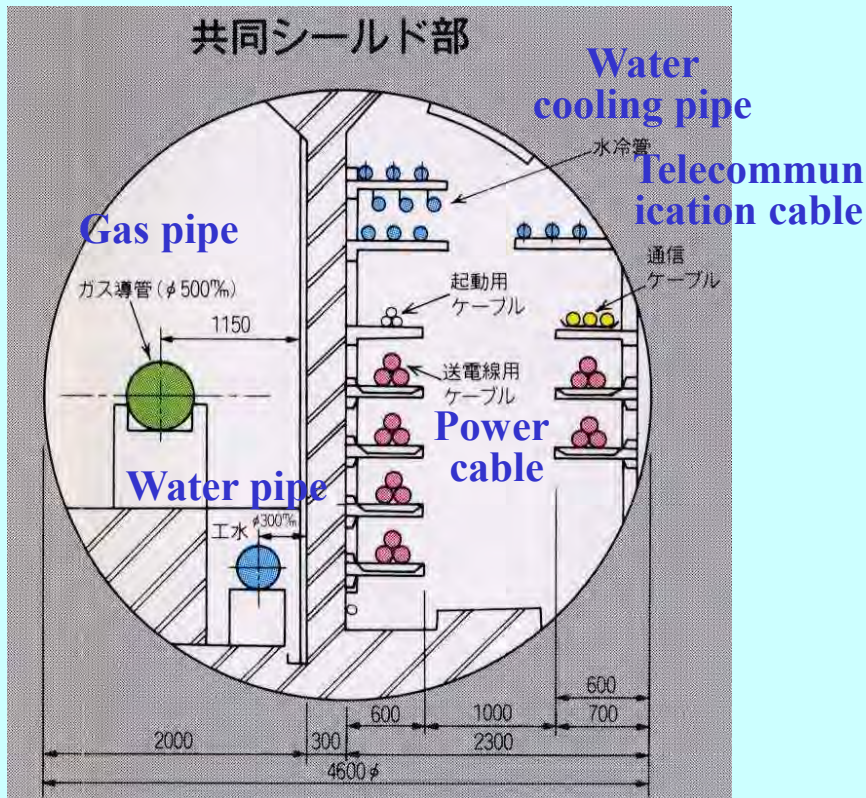

# An outline of NTT telecommunicational tunnel



Circular tunnel



Rectangular tunnel

# Lining

Segmental lining

Primary lining



Secondary lining



Steel Segment



# Typical cross sections of a gas pipe tunnel and a road tunnel

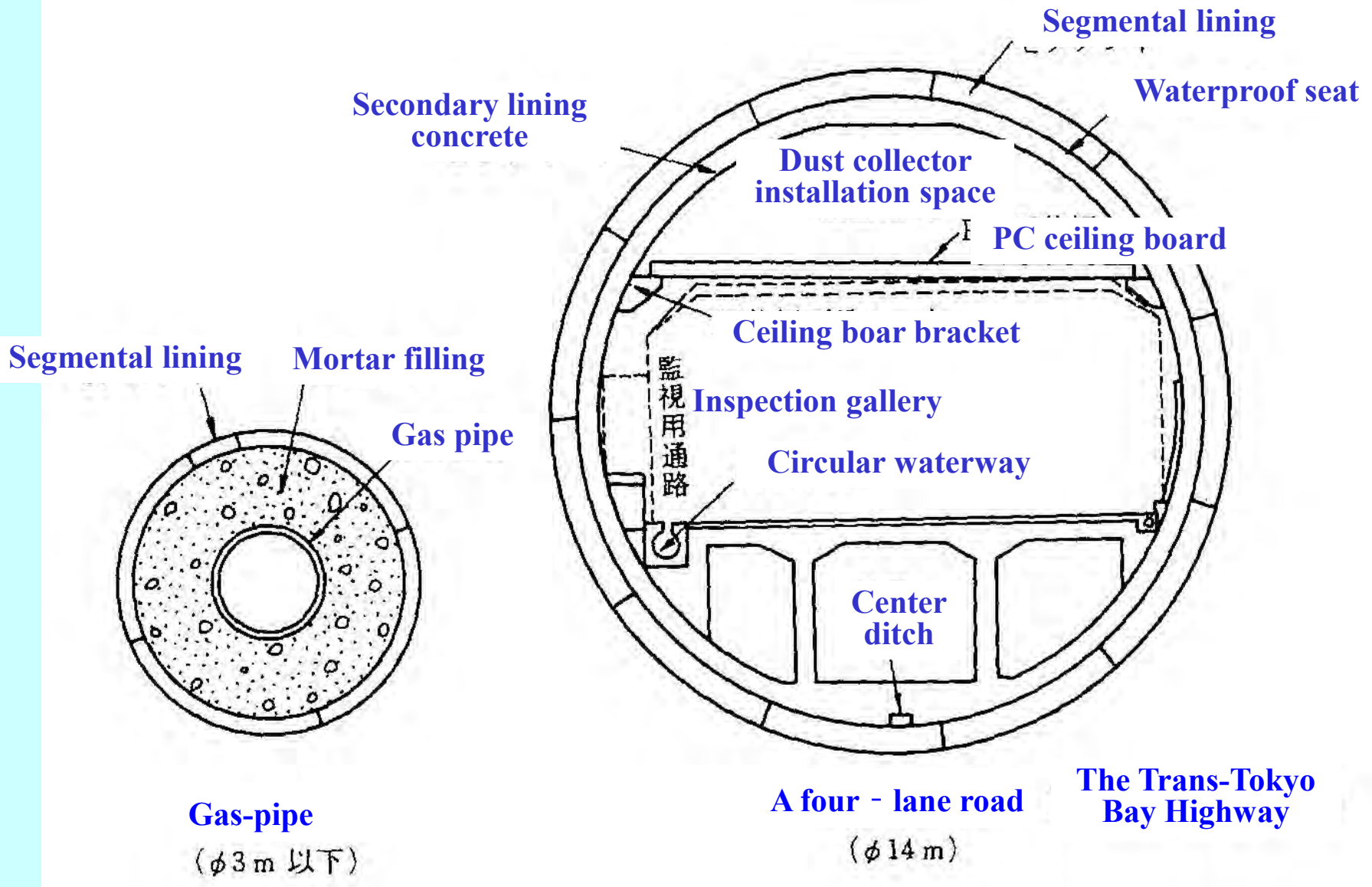

An example for a gas pipe tunnel

An example for a road tunnel

# Typical cross sections of a road tunnel

## An example of the Trans-Tokyo Bay Highway

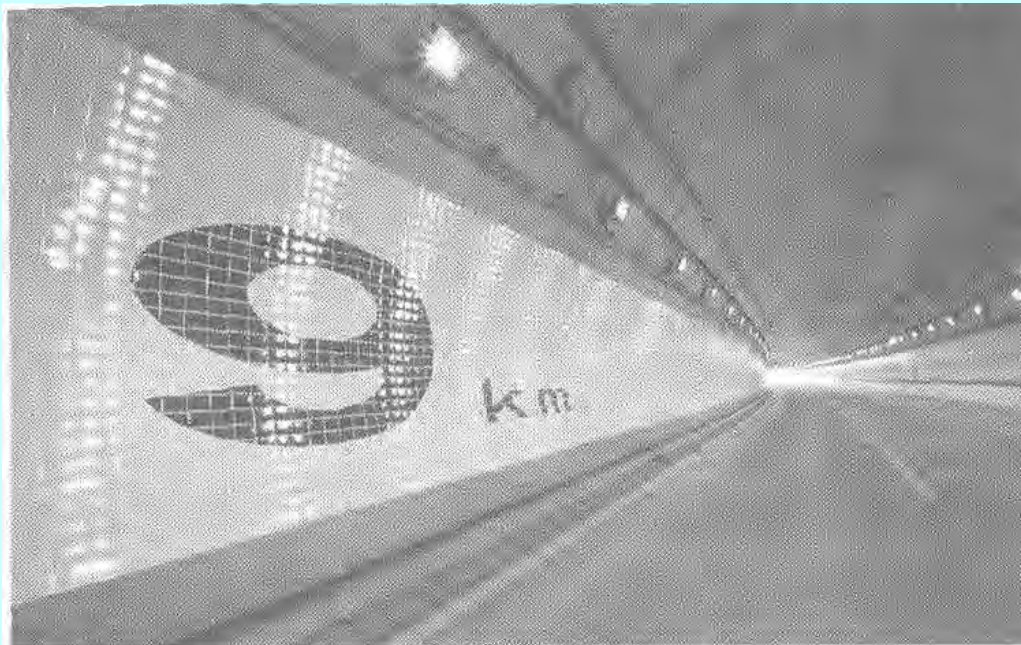

トンネル上半部の車道(総幅員10.5m)

**Roadway**

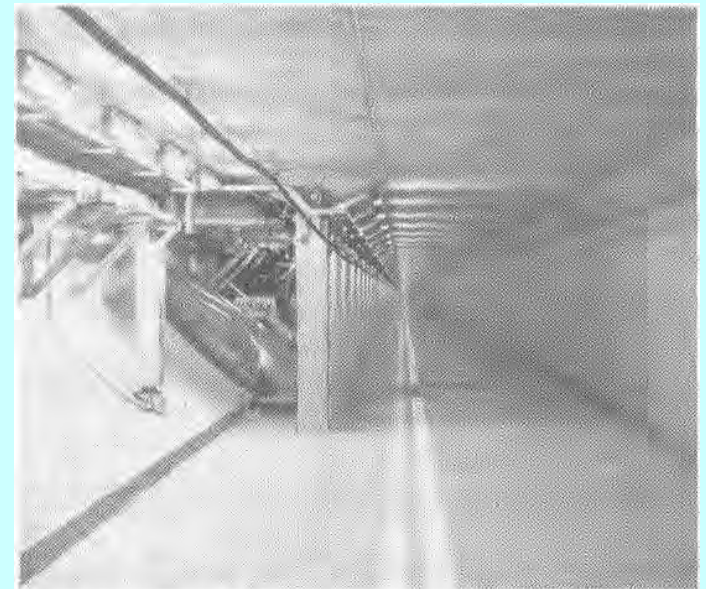

トンネル下半部の管理用通路  
兼避難通路

**Inspection gallery  
and  
Evacuation gallery  
(Lower half of a tunnel)**

# Examples of multiple use shield tunnels

A power cable tunnel

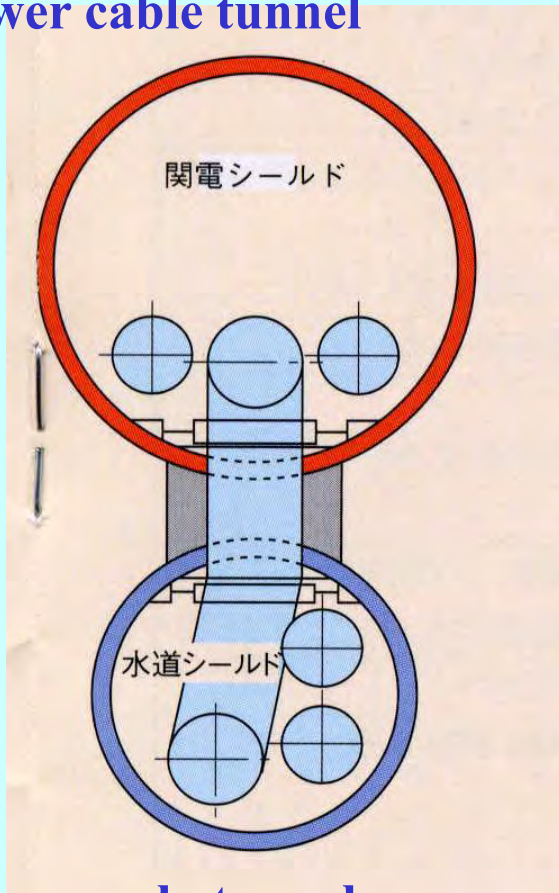

A water supply tunnel

Power cables

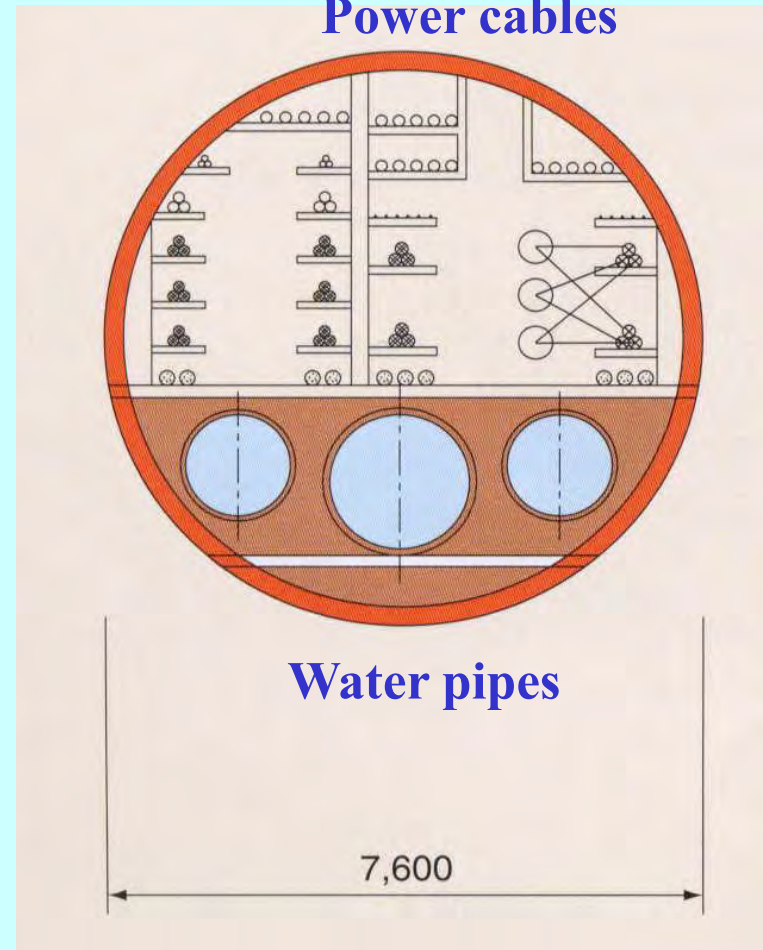

Water pipes

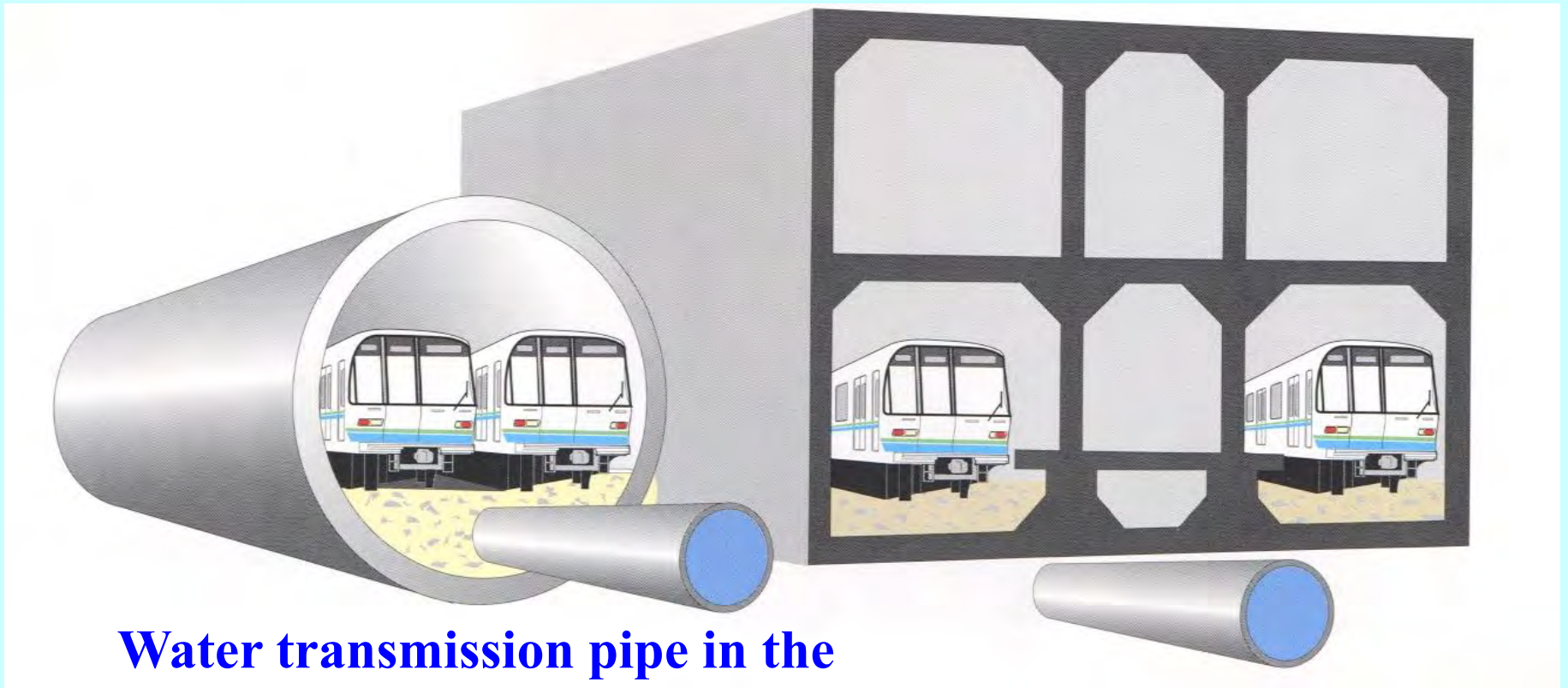

**Water transmission pipe in the  
invert**

Conceptual view of a traffic tunnel and  
a station of the Saitama rapid railway

## Setting situation of water transmission pipes

「導水管」設置状況





**Water transmission pipe  
under a station during construction**

# Winding Shield

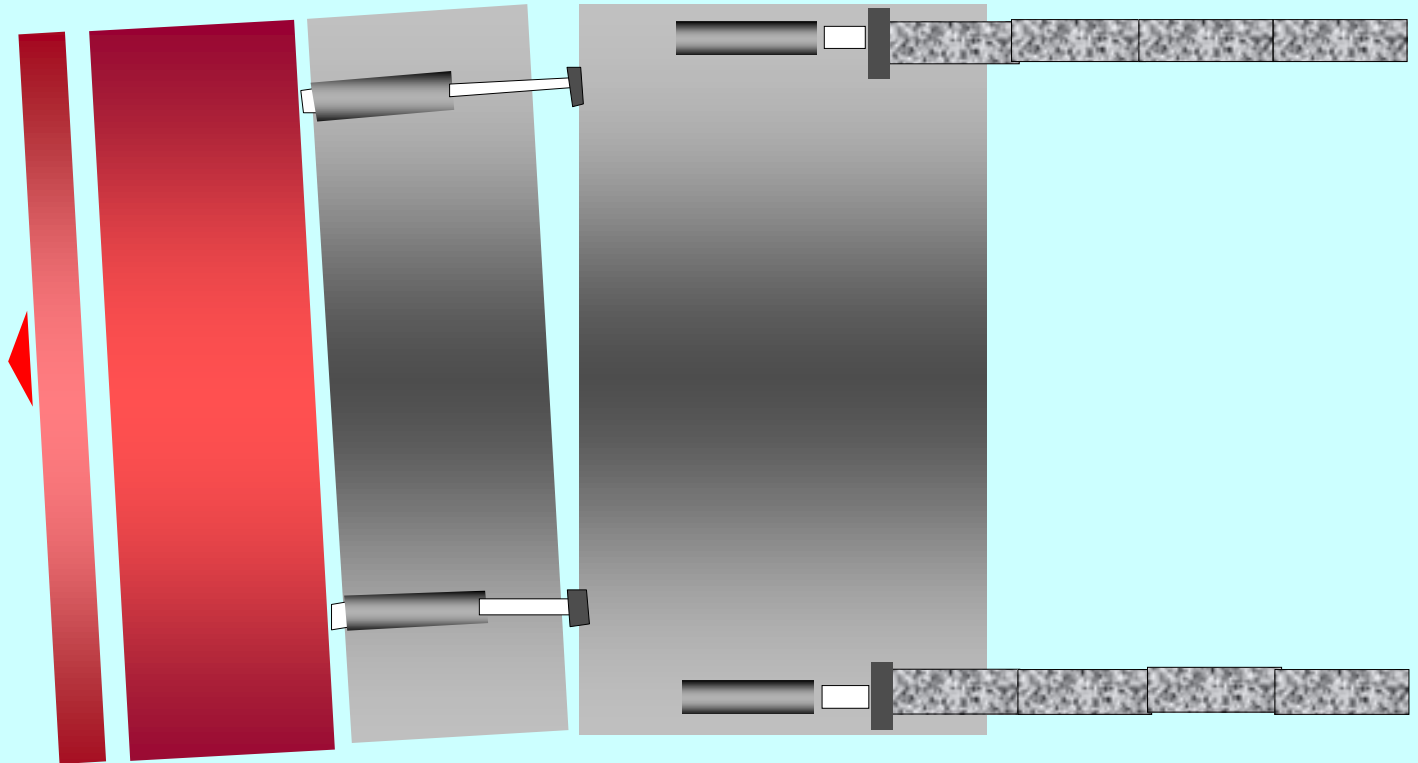

# Electric Power Tunnel

with Sharp Radius, Steep Grade in Large Depth

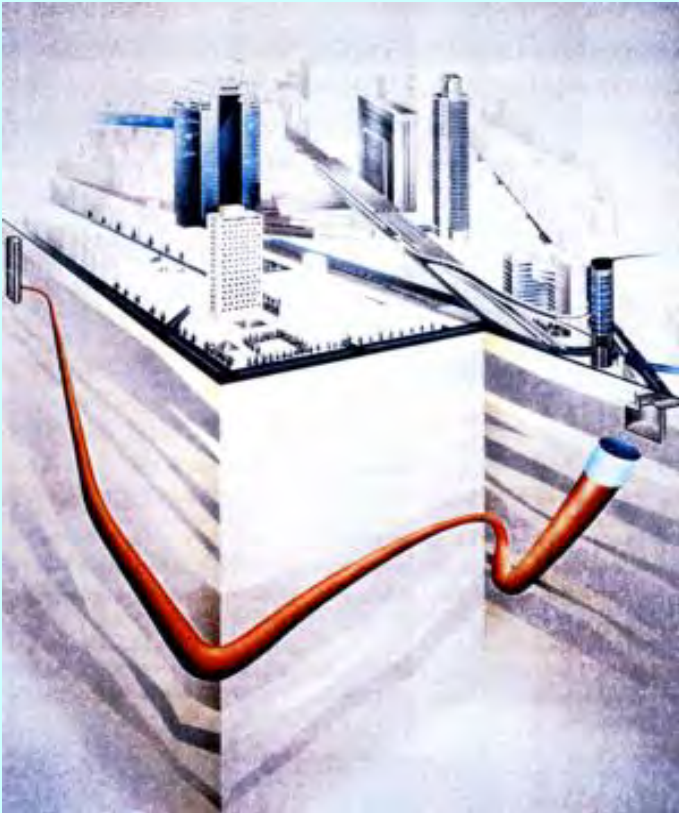

# Contents

- 1. What's a shield tunnel?**
- 2. How to make a shield tunnel?**
- 3. Recent record of shield tunnels in Japan.**
- 4. Design method of a shield tunnel.**
- 5. Examples of shield tunnel projects.**
- 6. SENS method**

### 3. Recent record of shield tunnels in Japan.

#### Achievement of a large face excavation and large overburden excavation

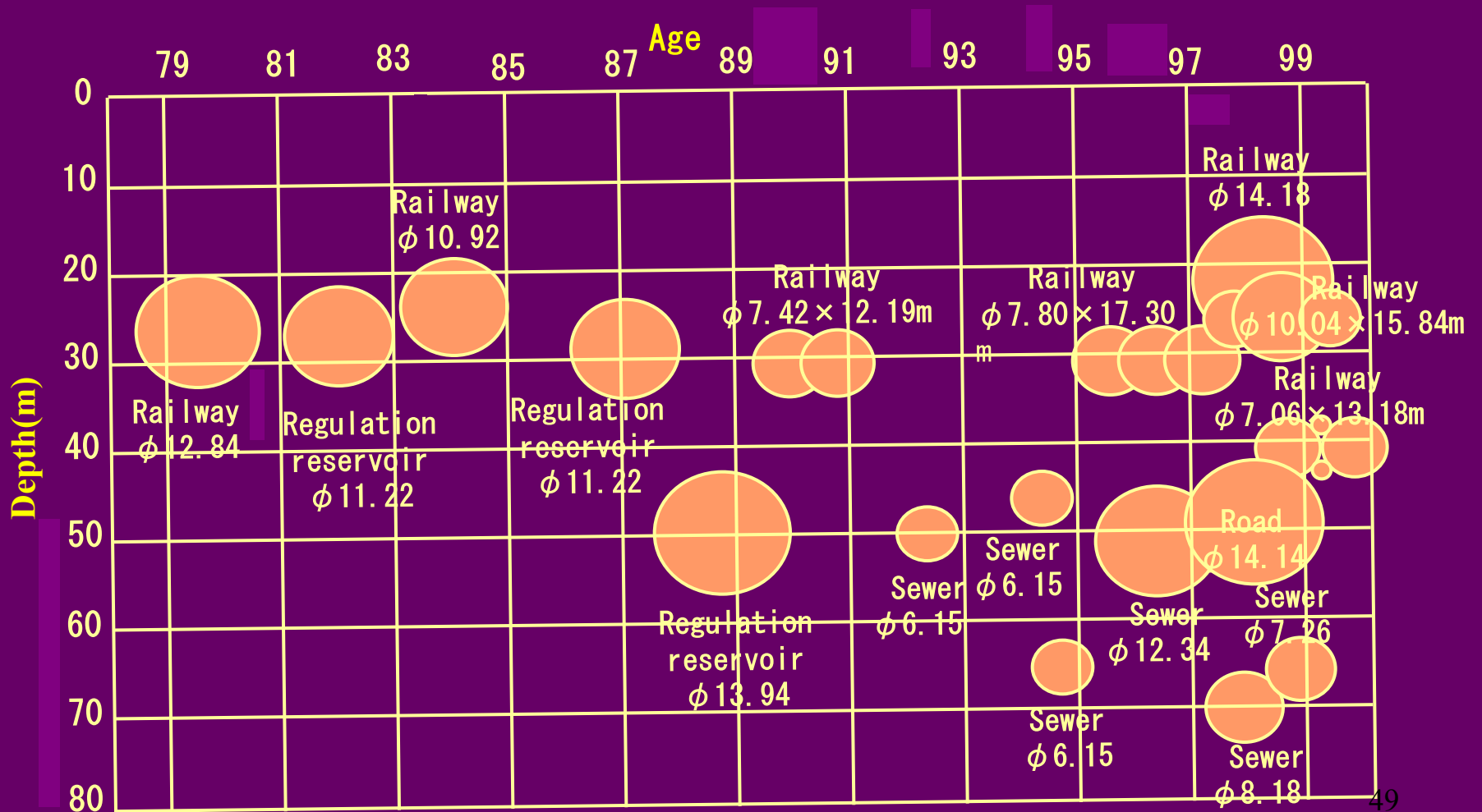

# Achievements of a sharp curve execution under high water pressure

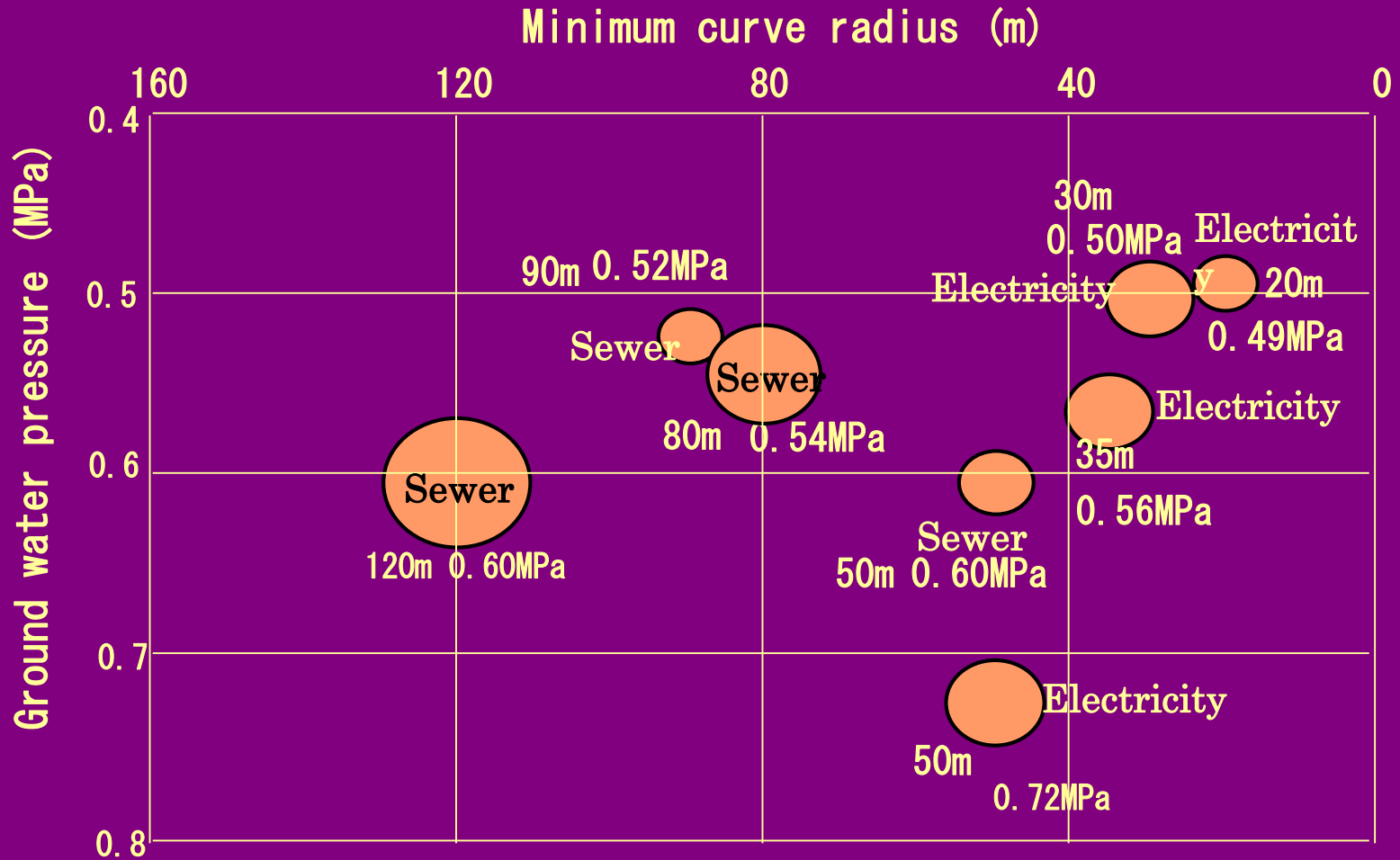

# Achievements of a long distance excavation

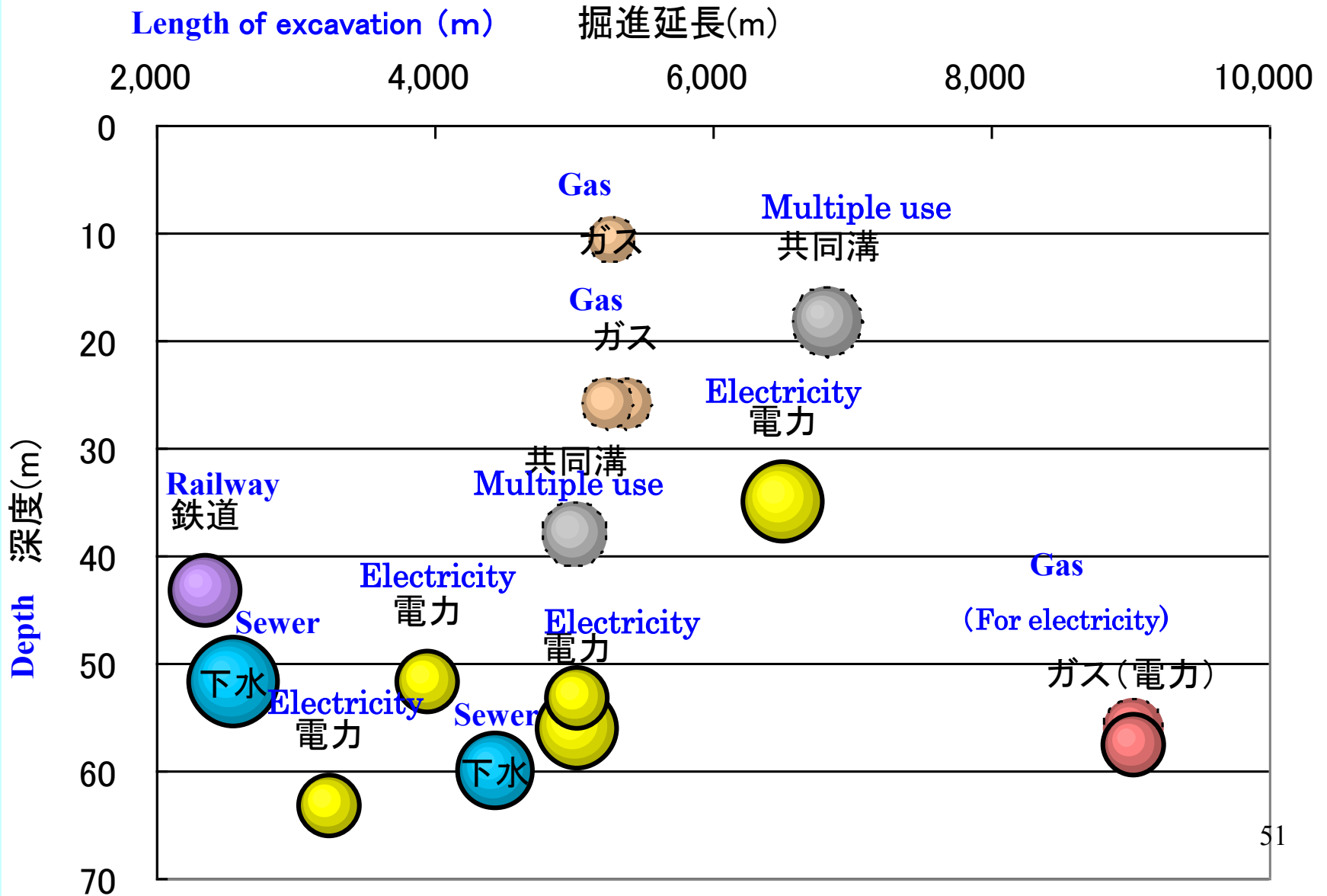

A tunnel for gas conduit connected east area to west area.

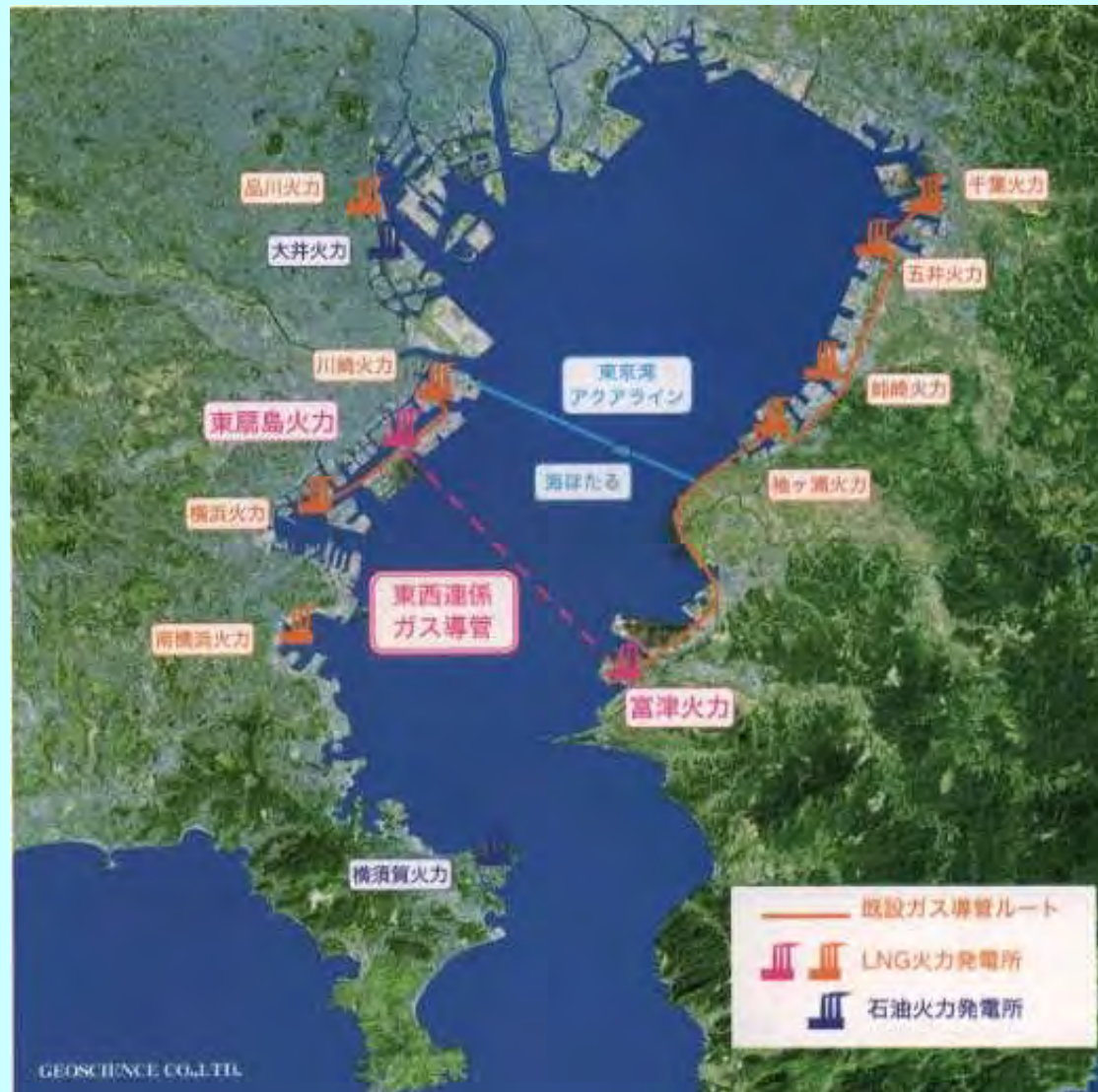

# A tunnel for gas conduit connected east area to west area.

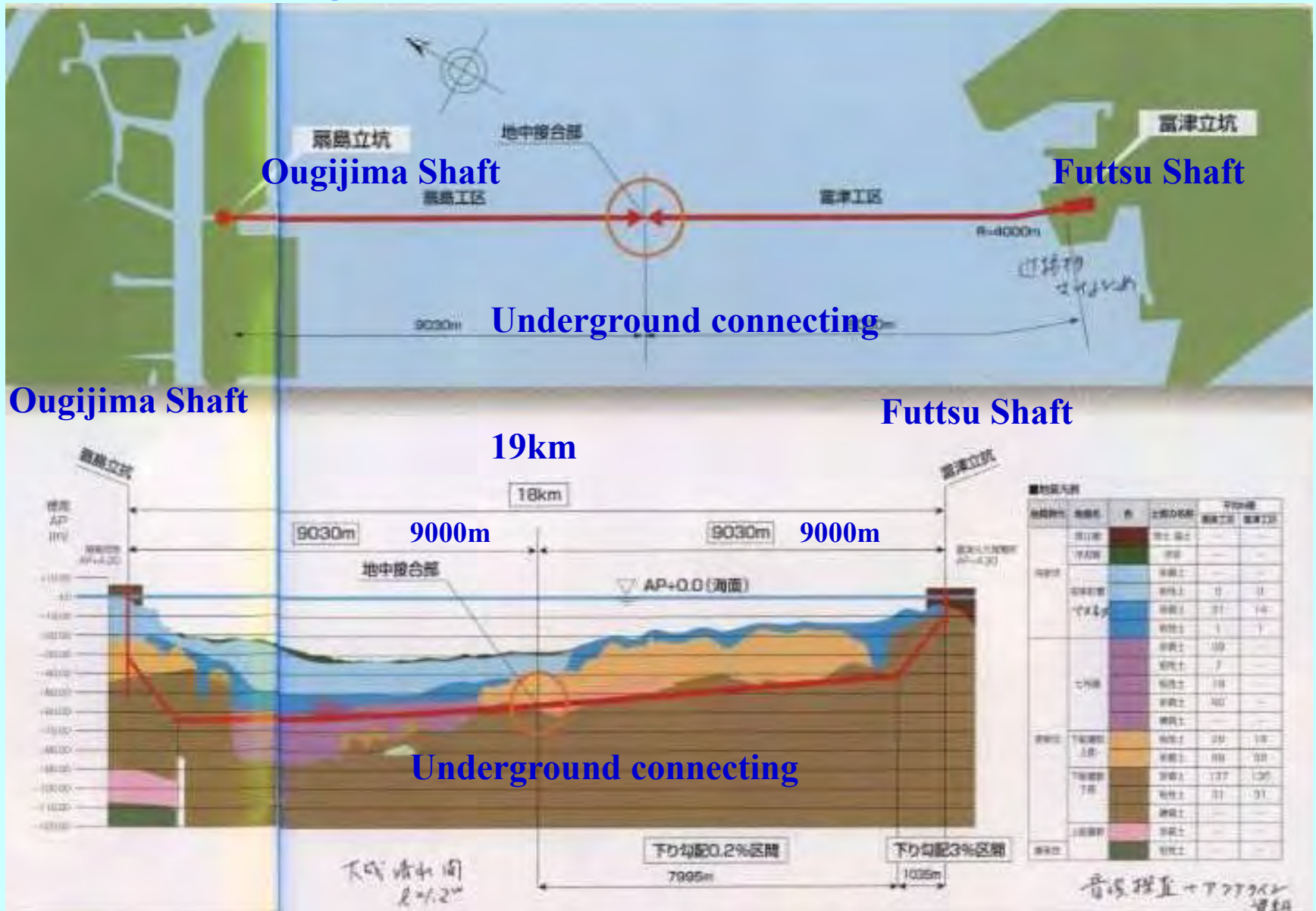

# Contents

- 1. What's a shield tunnel?**
- 2. How to make a shield tunnel?**
- 3. Recent record of shield tunnels in Japan.**
- 4. Design method of a shield tunnel.**
- 5. Examples of shield tunnel projects.**
- 6. SENS method**

# Design method of a segmental lining

Usual Calculation Method

Modified Usual Calculation Method

Structural model of segmental lining:

Solid ring with fully flexural rigidity

$\zeta$        $\eta$

Interaction model between ground and tunnel lining:

Ground reaction

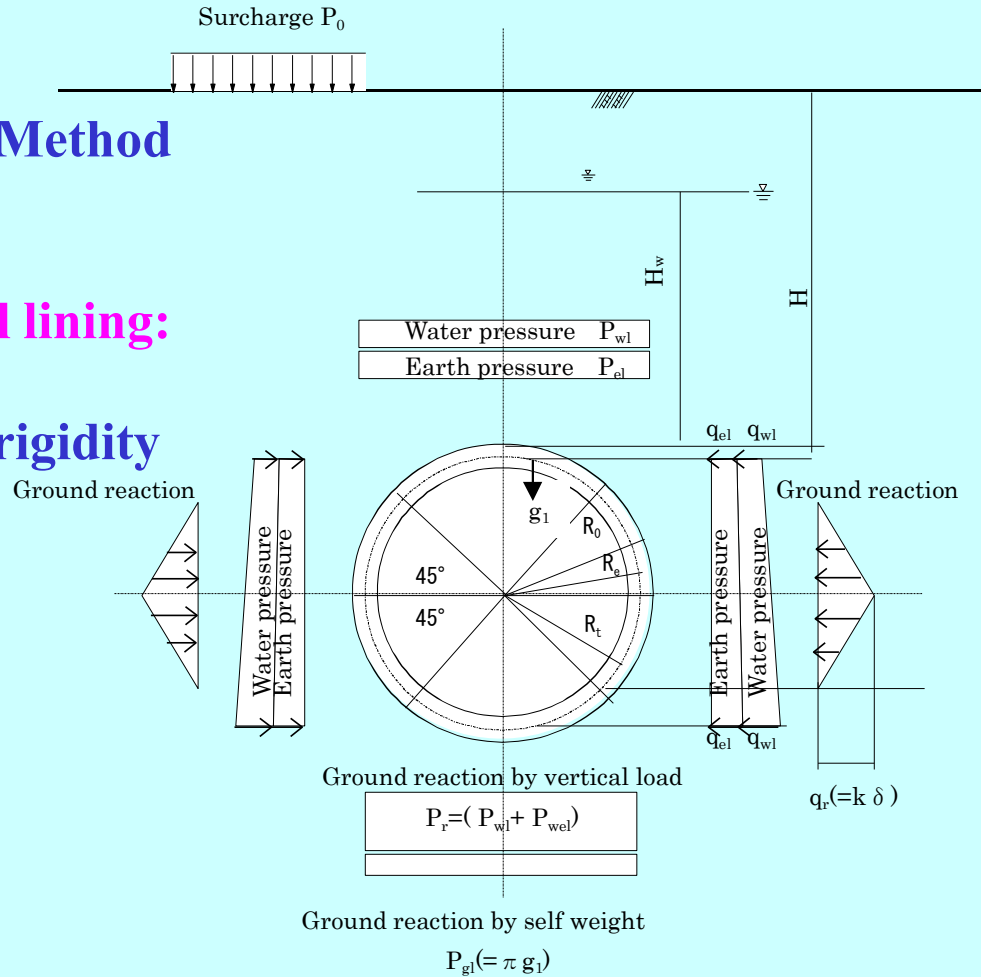

# Design method of a segmental lining ( Railway Tunnel )

Structural model of segmental lining:

Beam-spring model

Interaction model between ground and tunnel lining:

Full-circumferential spring model

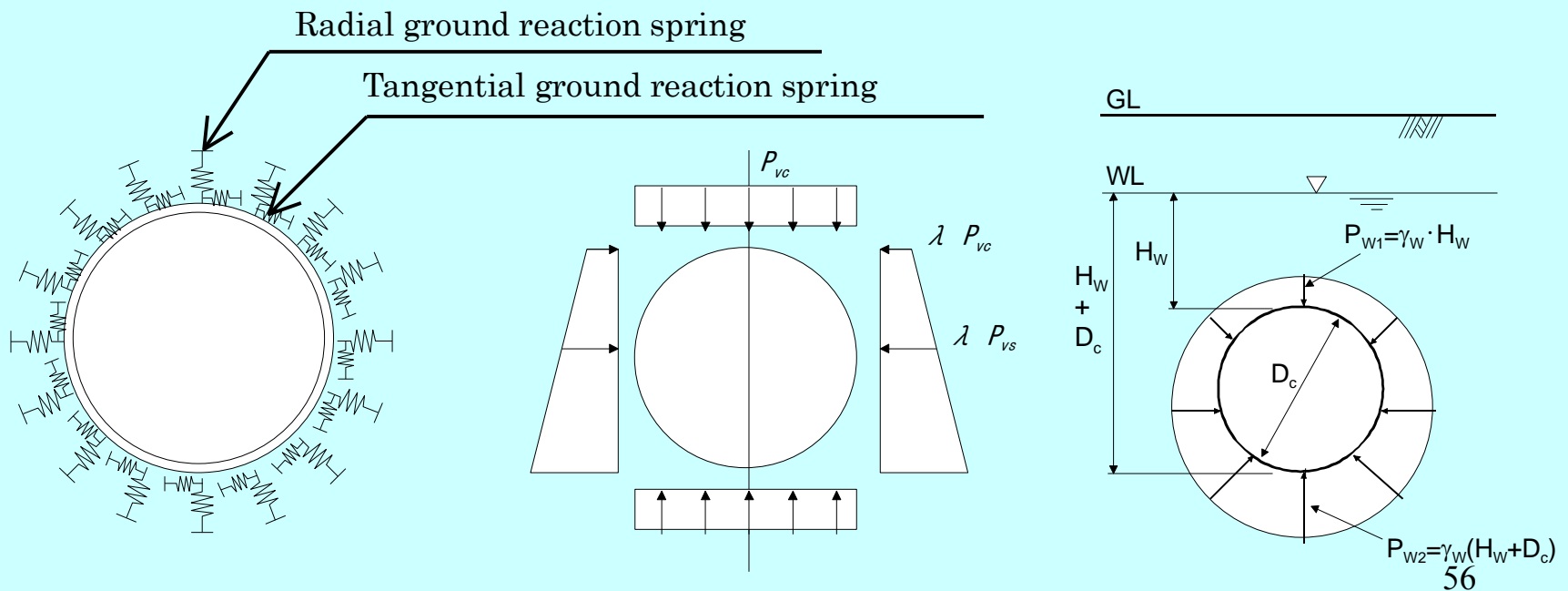

# Earth pressure distribution (Open type shield)

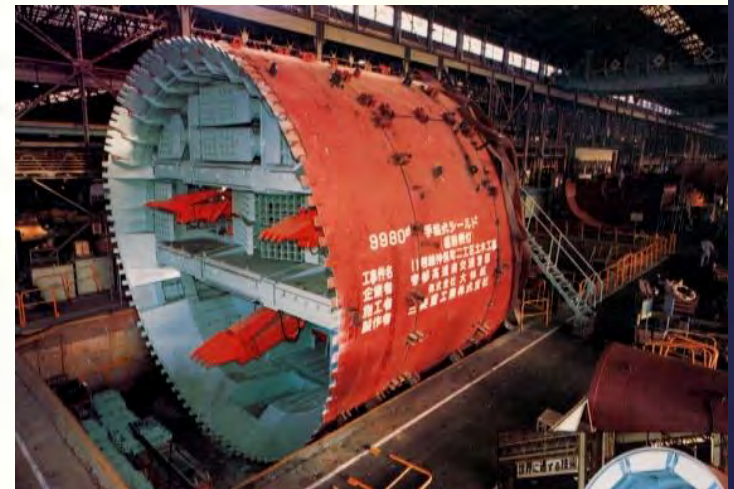
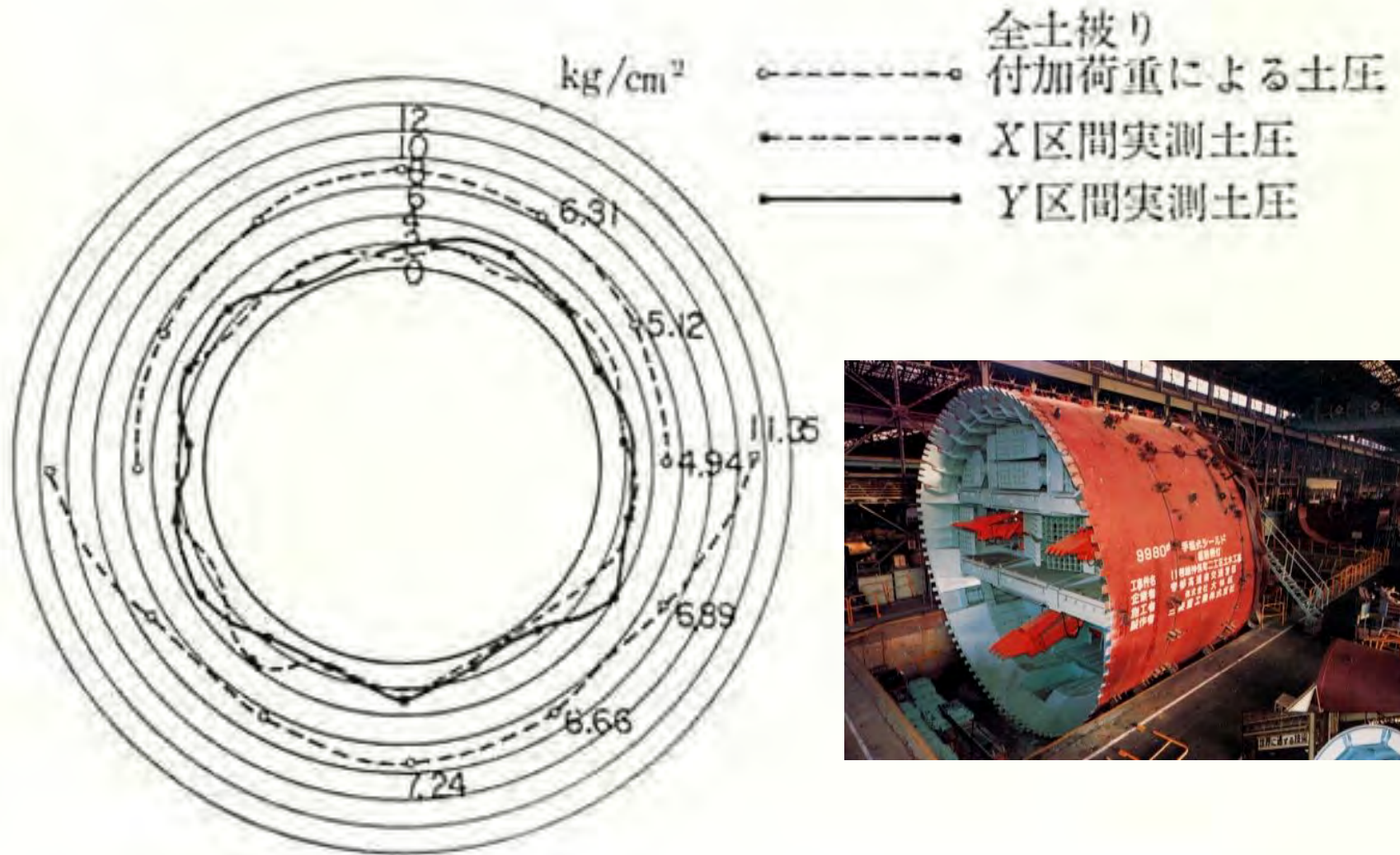

# Results of measurement in a sandy layer (Earth pressure, Water pressure)

(Closed type shield)



## Legend

- Earth pressure
- Water pressure

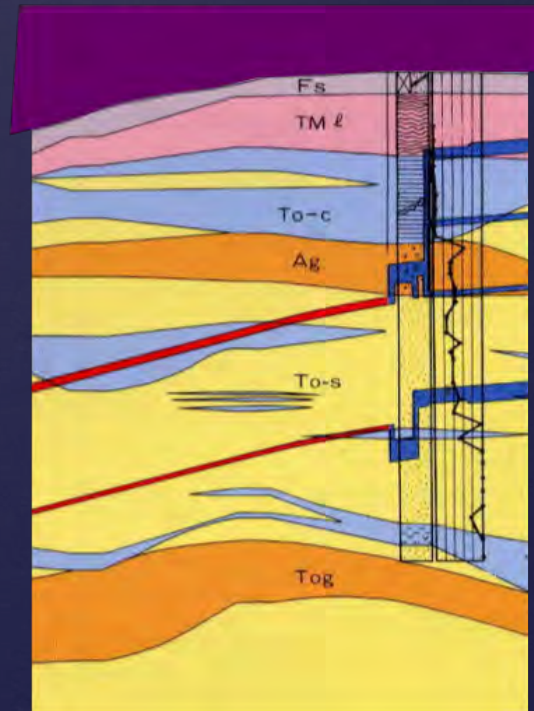
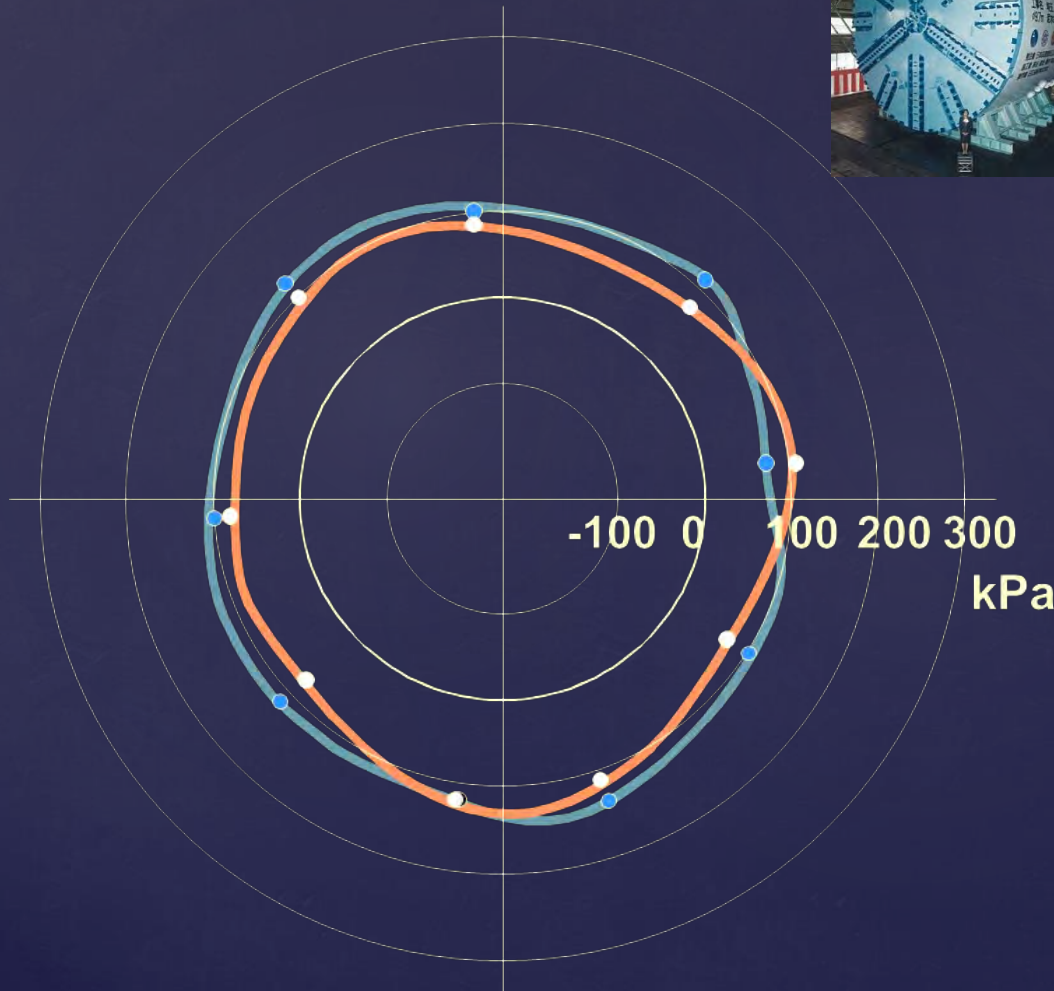

# Effect of back-fill grouting

## Diluvium Sandy soil

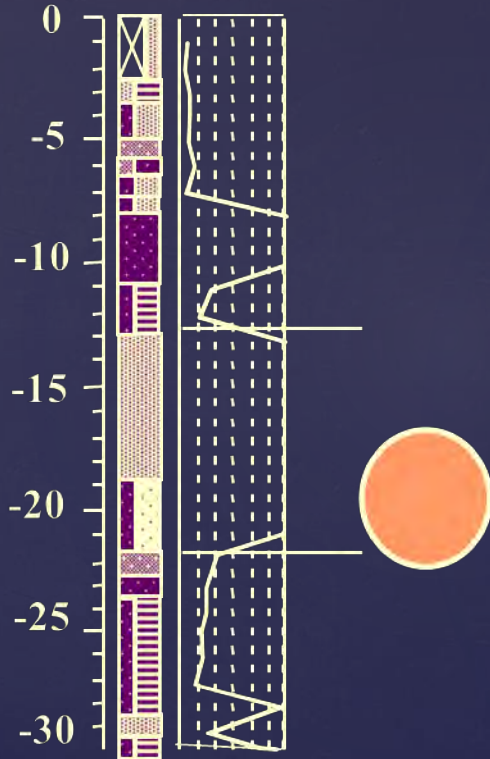

## Diluvium Clayey soil

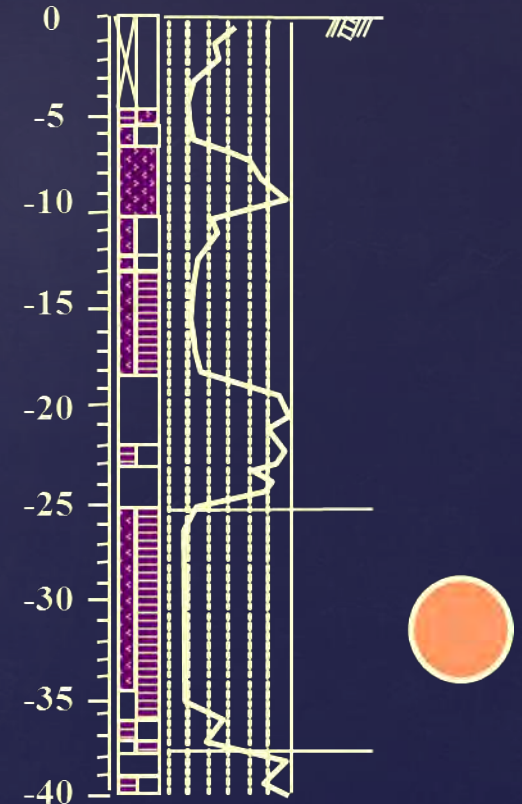

# Plan of back-fill grouting

	Case1	Case2
<b>Plan injection pressure</b>	<b>150kPa</b>	<b>50kPa</b>
<b>Plan injection rate</b>	<b>139%</b>	<b>100%</b>
<b>Material of back-fill</b>	<b>Standard arrangement</b>	<b>Low strength arrangement</b>
<b>Injection method</b>	<b>Normal</b>	<b>When injection pressure become bigger than plan pressure, the injection is stopped.</b>

# Earth pressure acting on segment (Diluvium Clayey Soil)

- 5 days after tail passing
- 5 months after tail passing
- Design earth pressure

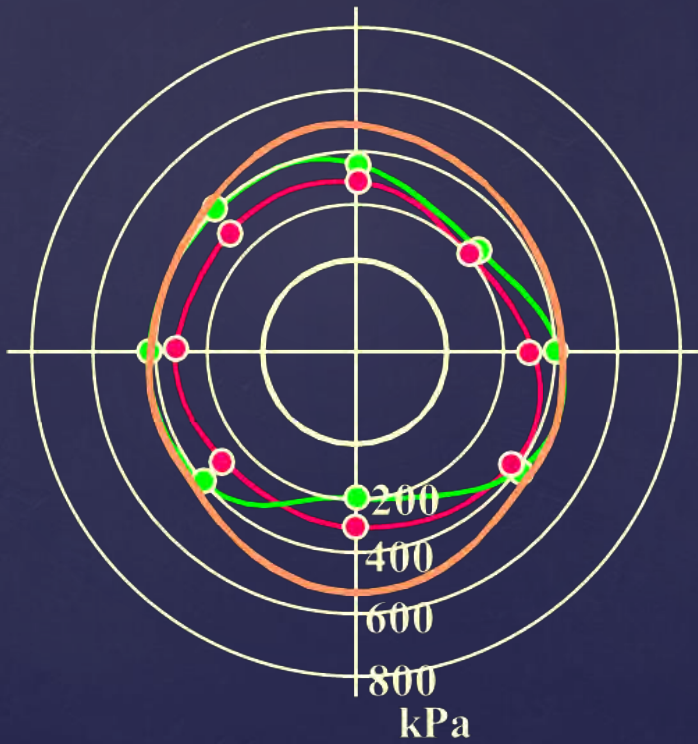

Case 1

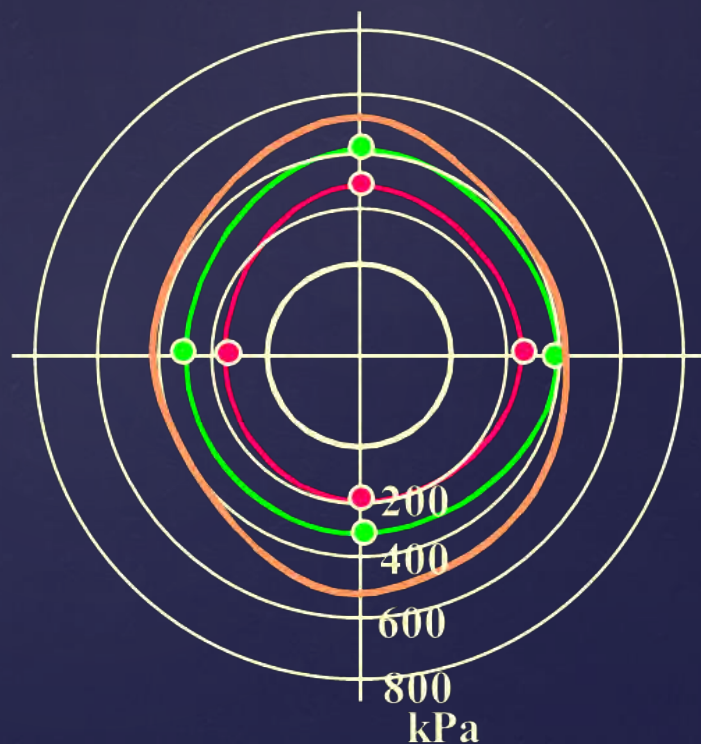

Case 2

# Earth pressure acting on segment (Diluvium Sandy Soil)

5 month after tail passing

● Effective earth pressure

● Total earth pressure

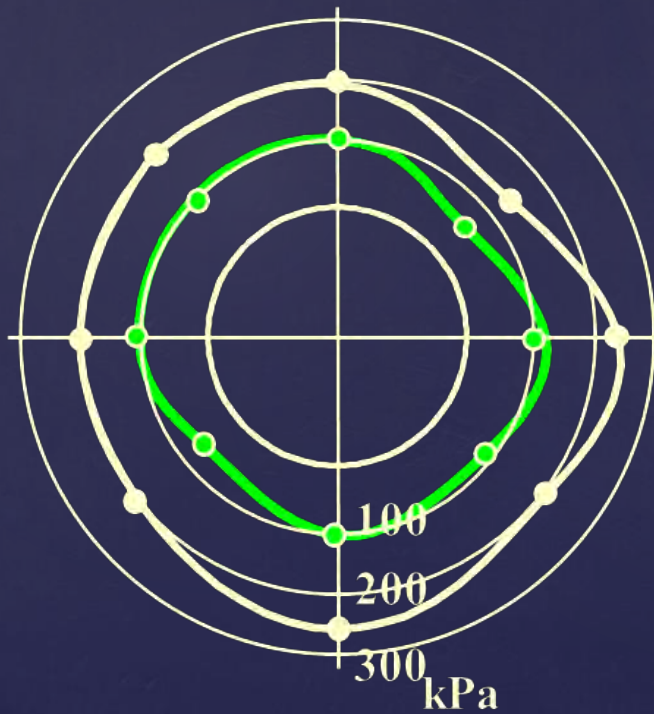

Case 1



Case 2

# Design model for the pressure of back-fill grouting

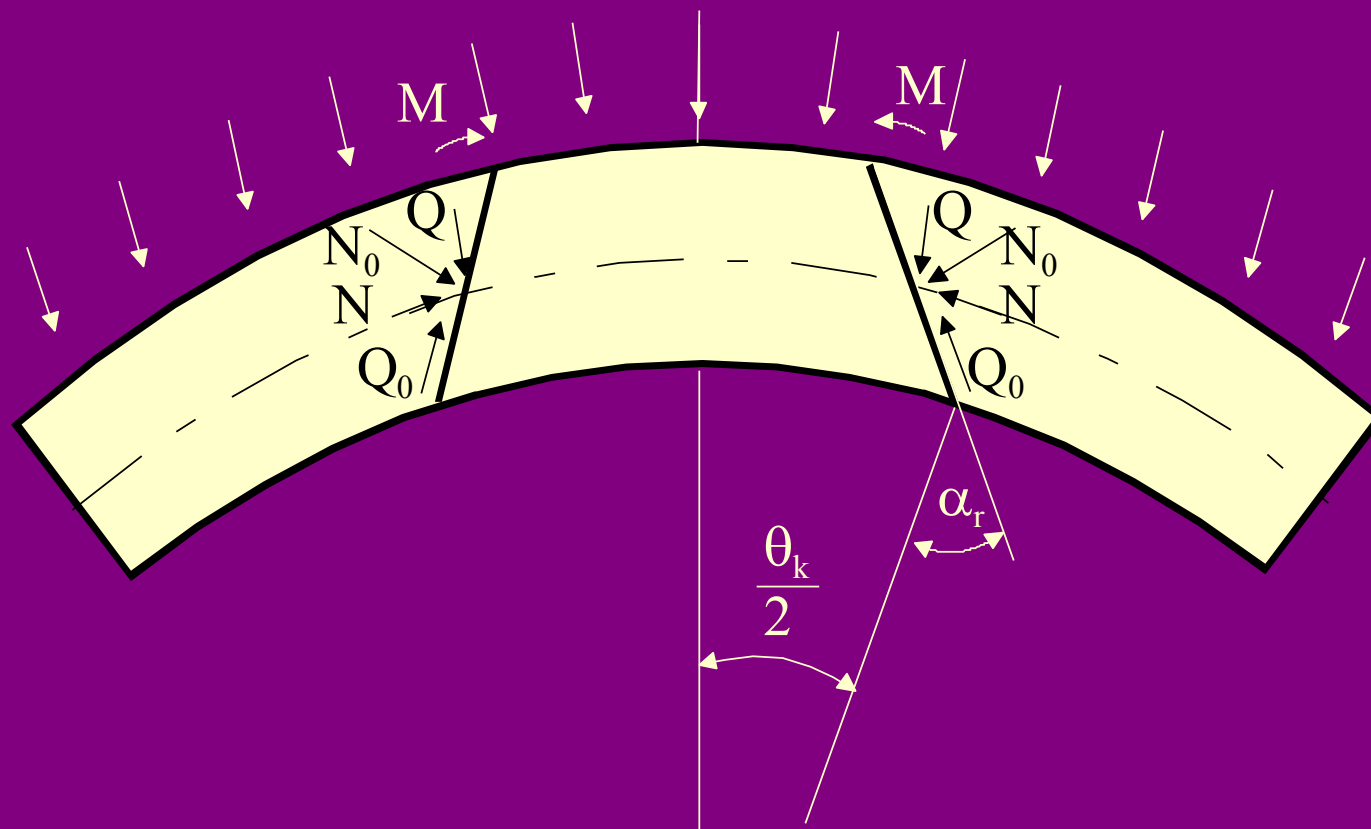

# Design model for segments in sharp curve

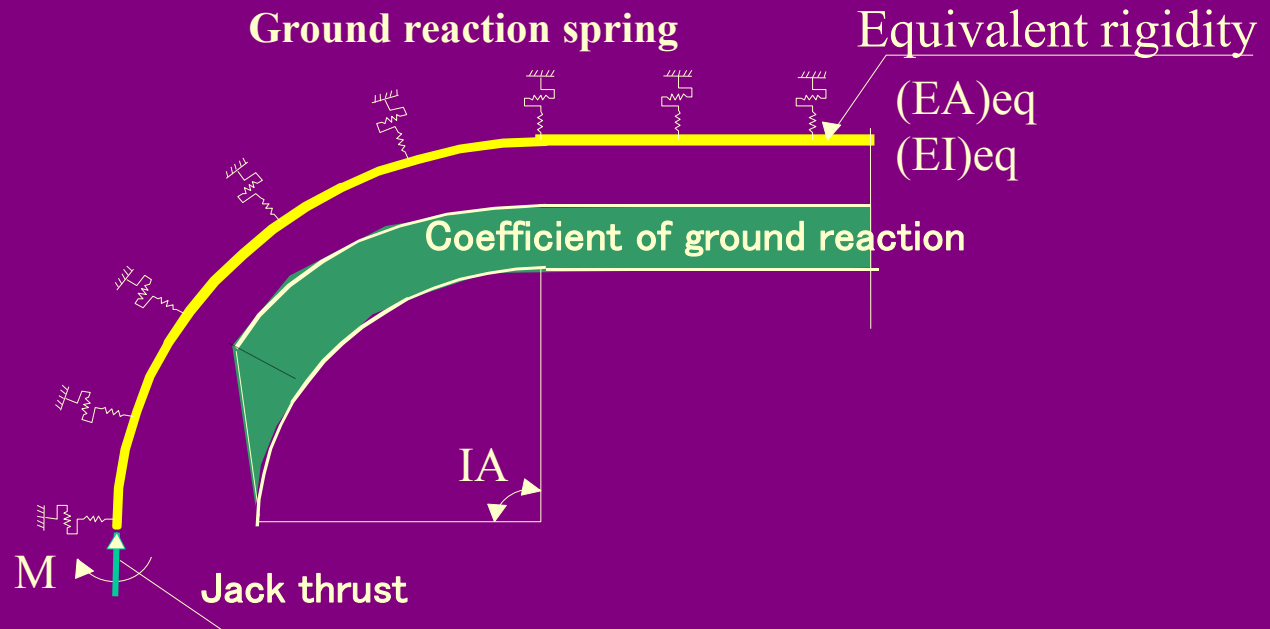

## **Factors causing damage of segment**

- 1) Cracks caused by jack thrust**
- 2) Cracks caused by consolidation settlement around the tunnel**
- 3) Cracks caused by the adjacent construction work to the tunnel**

# Damage due to Construction Load

Crack due to a difference  
(Longitudinal section)

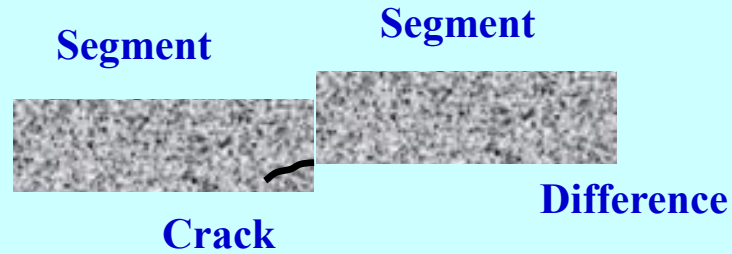

Crack due to a gap

Ring joints aren't on a same plane

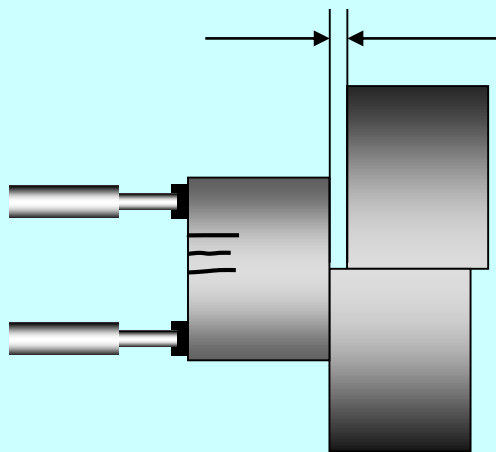

Crack due to a difference  
(Cross section)

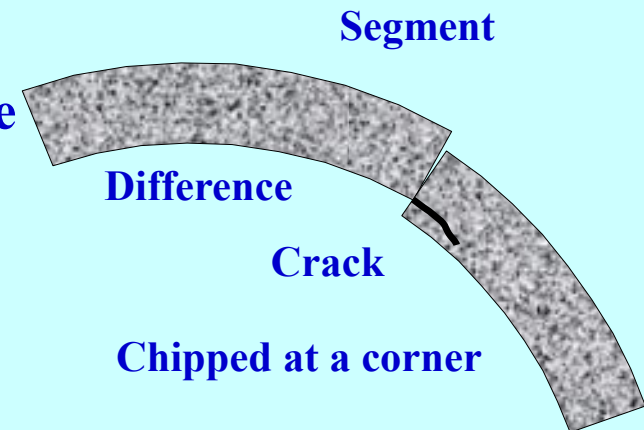

Crack due to a difference and a gap

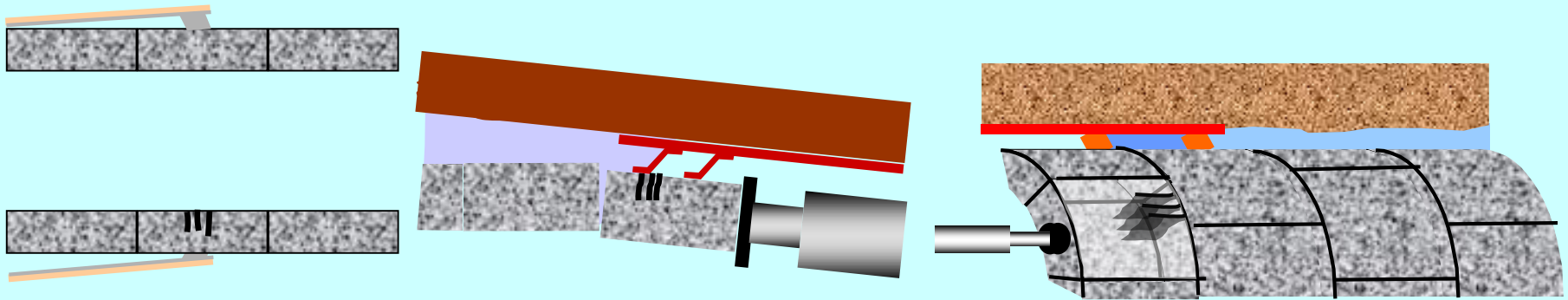

**Crack due to contacts of the shield tail and segments**

**Crack due to increased friction by hardened tail graut**

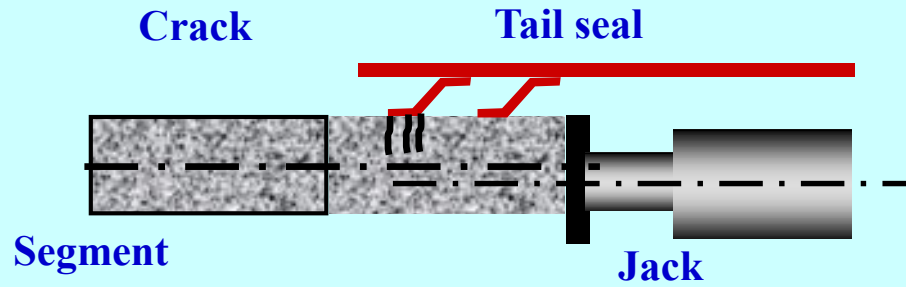

**Crack due to eccentric thrust of a jack**

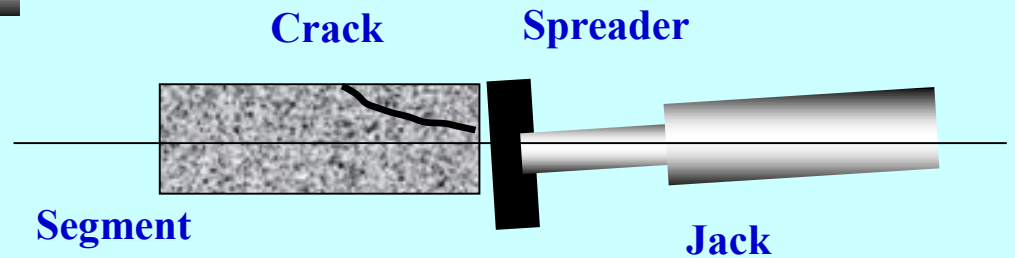

**Crack due to a inferior spreader**

# Factors causing damages of segments in the construction procedure

- 1) Accuracy of assembly of segments
- 2) Control of the attitude of a shield
- 3) Accuracy of manufacture of shield

## Countermeasures for prevention of damages of segments

- 1) The designer of segments should reinforce them by estimating errors on manufacture and construction procedures.
- 2) The designer should inform the construction foreman of the condition of the design for segments.

# Contents

- 1. What's a shield tunnel?**
- 2. How to make a shield tunnel?**
- 3. Recent record of shield tunnels in Japan.**
- 4. Design method of a shield tunnel.**
- 5. Examples of shield tunnel projects.**
- 6. SENS method**

# An example of a deep tunnel under high underground water pressure



# Outline of the project

## Plan of the project

- ① 2 mud transport pipes
- ② Deep-fixed slop
- ③ With inspection gallery
- ④ Non secondary lining



# Outline of the construction

## Total length of the tunnel

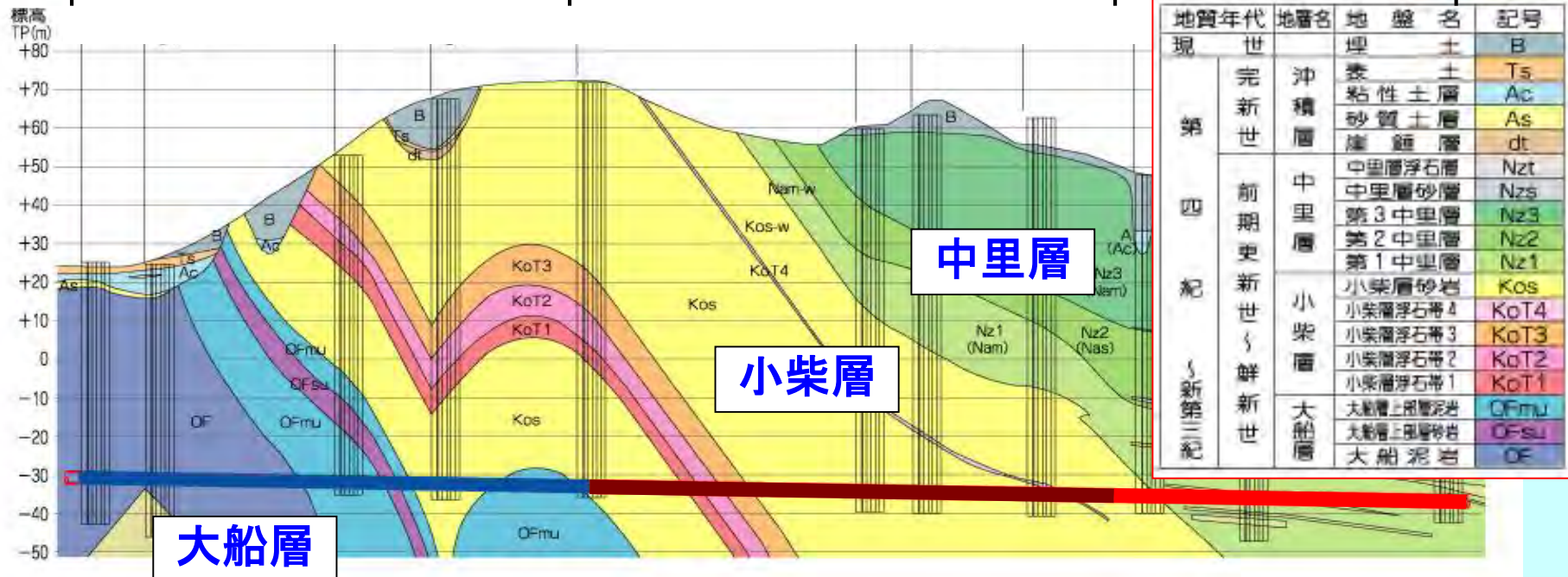

Plan view of the tunnel line and ground profile

# Plan

## Countermeasure of the long distance excavation

- Different height type bits
- Wear detector bits
- Rescue bits

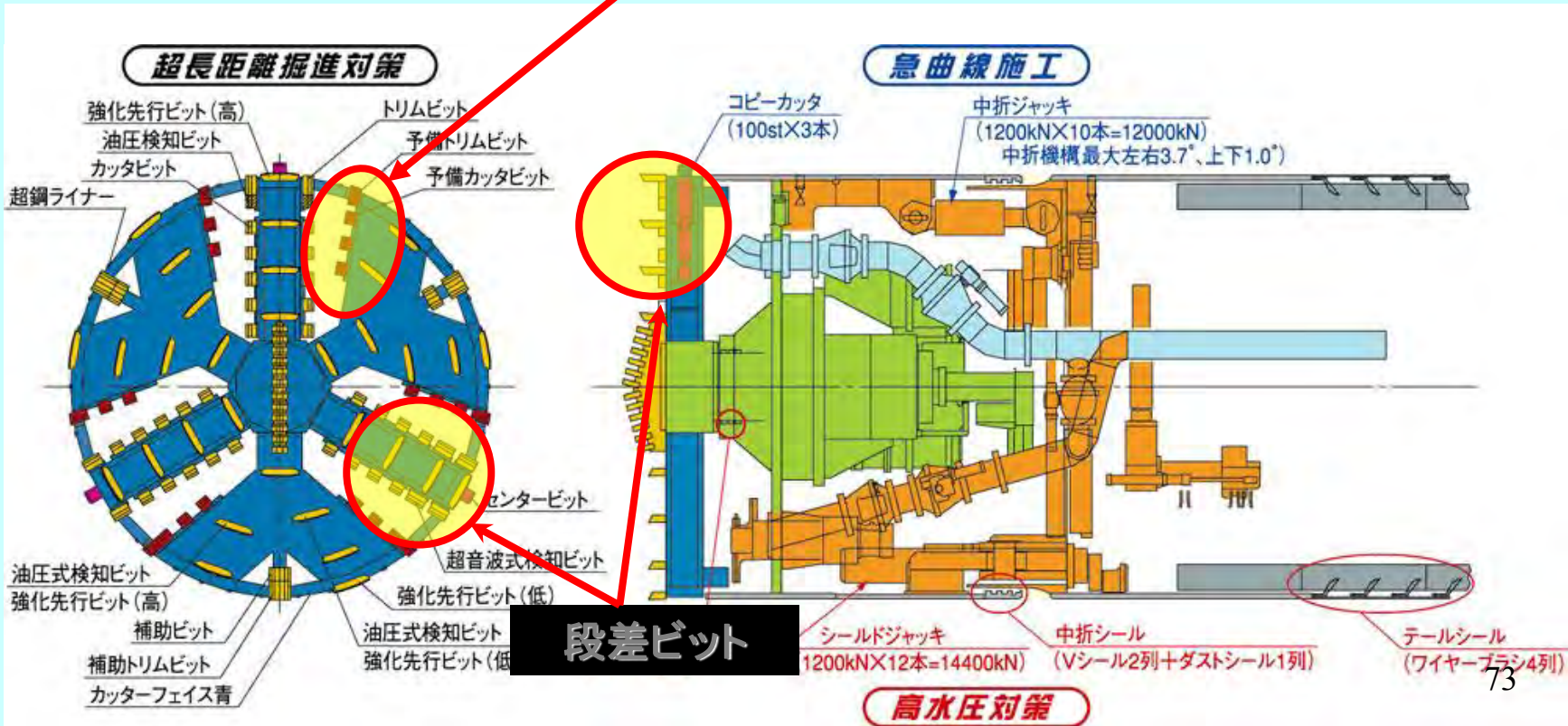
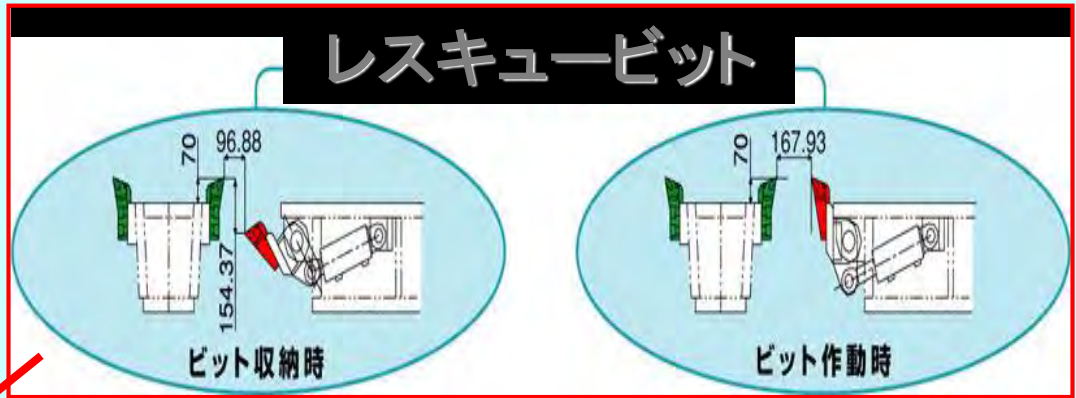

# Plan

## Countermeasure of the high water pressure

- 4 layers type tail seal system
- Cutter bearing seal for high water pressure
- Increase of trust capacity  
(Two times strong of standard)

4 layers type  
tail seal  
system

### Cutter bearing seal for high water pressure

- ①VDシール3段(NBRゴム)
- ②土砂シール反転防止金具

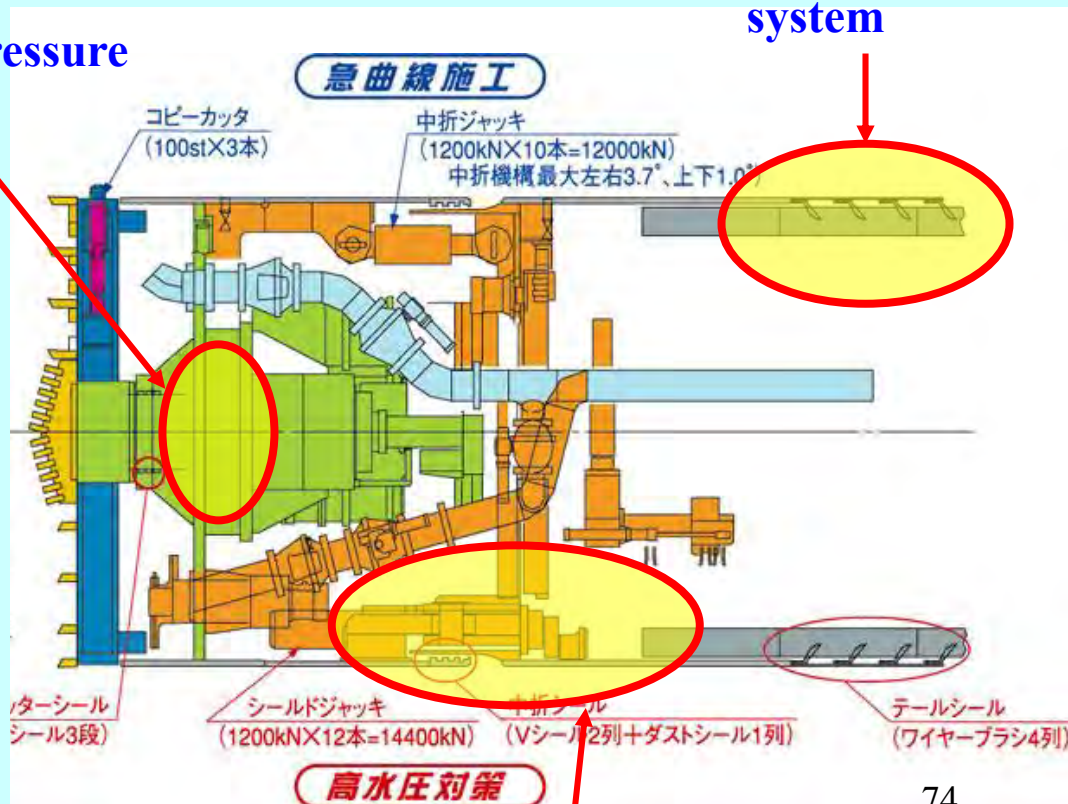
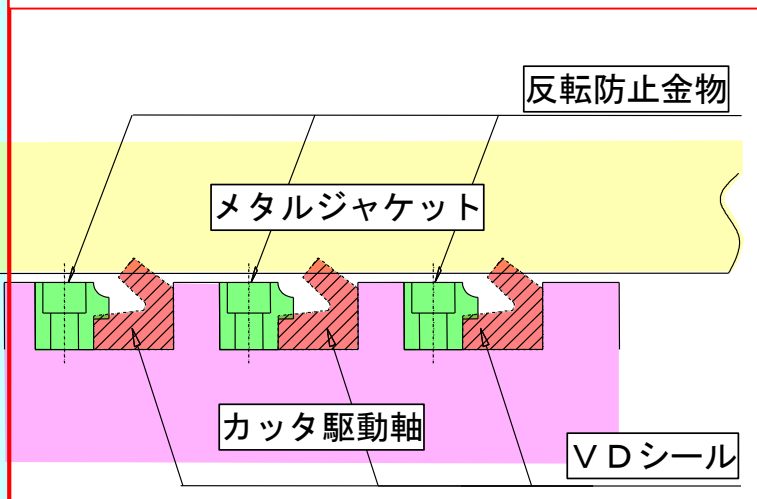

Increase of trust capacity

**Plan**

# Muck removal facilities (Slurry shield system)

- ① Gravel crusher measured to high water pressure
- ② Slurry discharge pump measured to high water pressure



**Slurry discharge pump measured to high water pressure (1.5MPa)**



**Normal crusher (0.5MPa)**



**Crusher measured to high water pressure (1.0MPa)**

- ① Non secondary lining: Decrease number of joint boxes, RC plane segment
- ② For long distance excavation: Wedge-pin type joint for workability
- ③ For high water pressure: Sealing material corresponding to 0.9MPa high water pressure, 0.9MPa

## Wedge-pin type joint

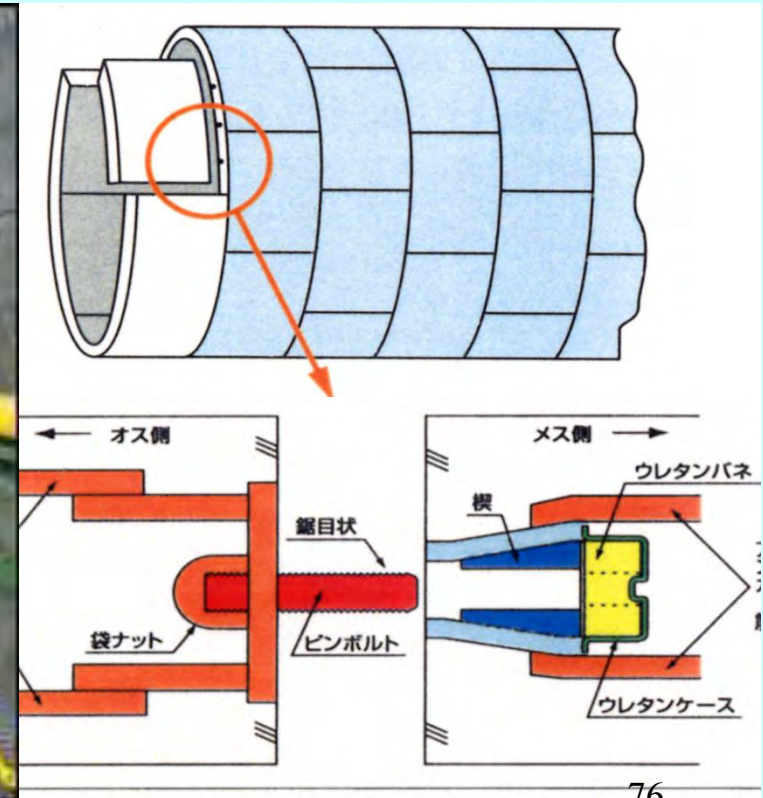
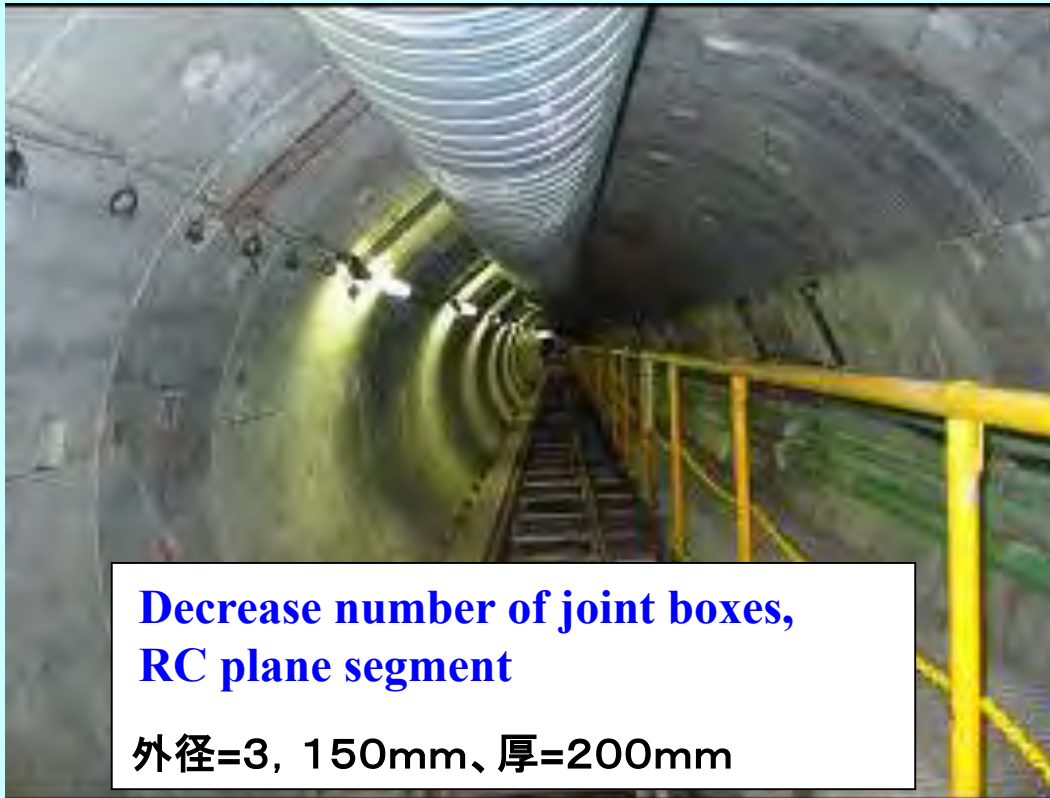

# Result

## Thrust force of shield jacks

- ① Slurry pressure at face: Max.0.86MPa, same as results of the advance investigation
  - ② Total thrust force: Above the plan, Max.13,000kN (90% of the capacity)
- Possibility: Appearance of a sandstone, Tightness by fine sand

Water pressure at the face

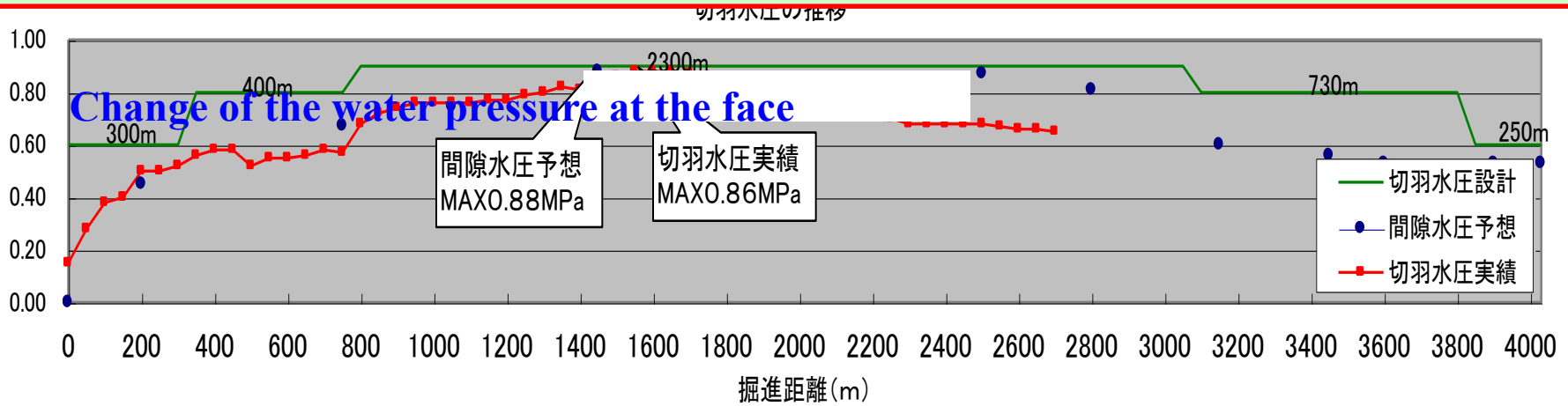

Total thrust force

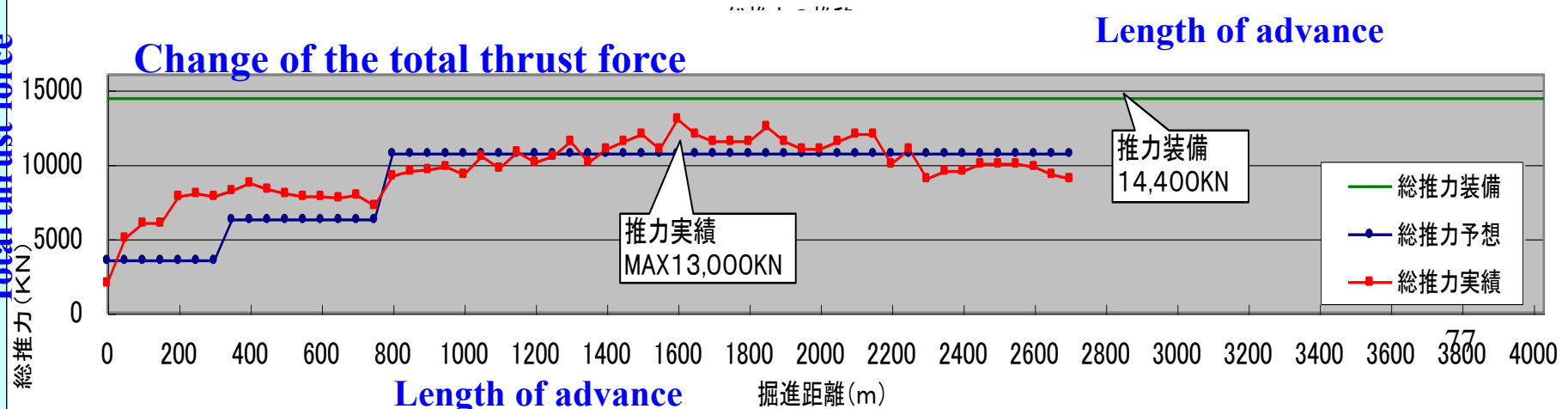

# Result

### 総推力の推移

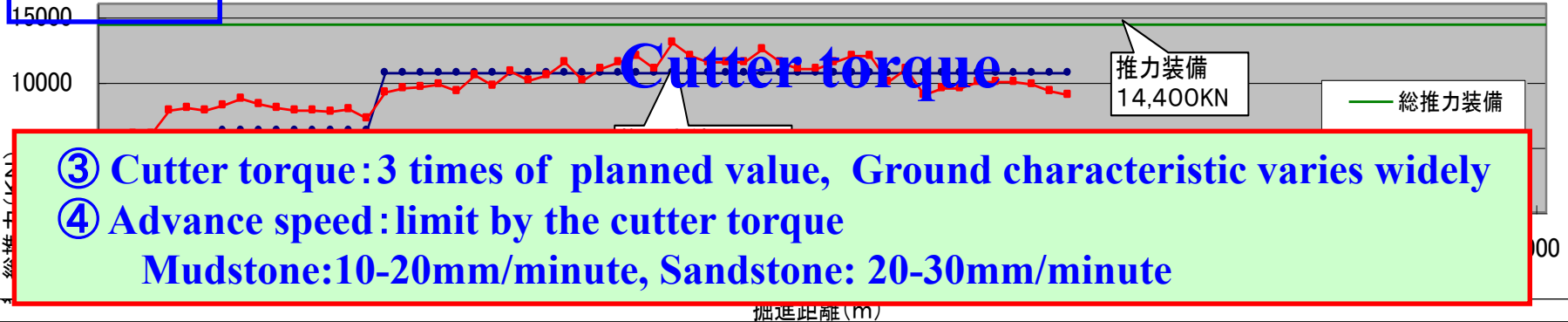

### カッタートルクの推移

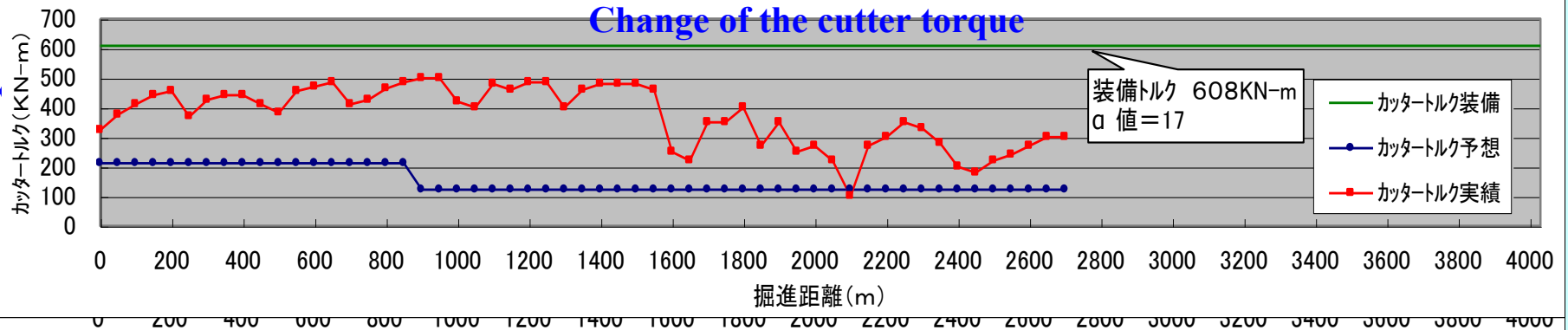

### Change of the advance speed

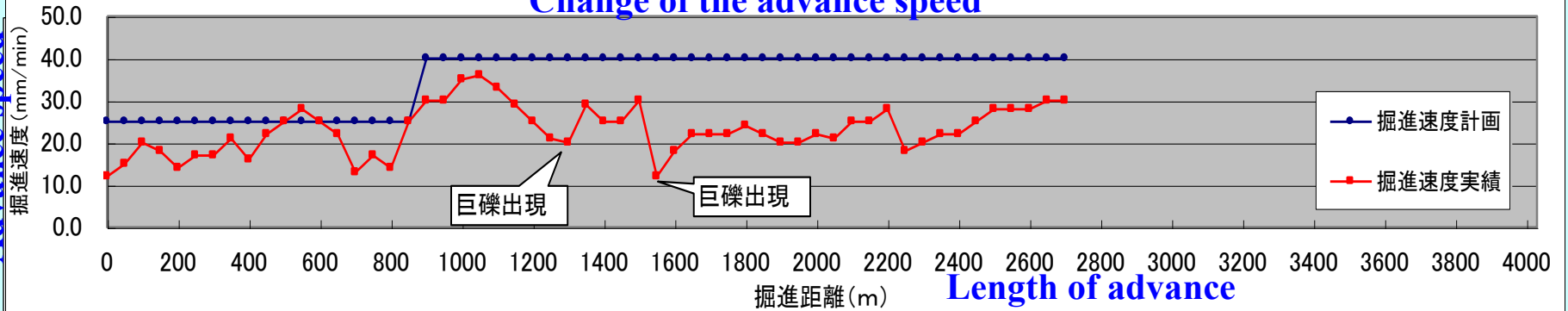

### 裏込注入圧の推移

# Problems of constructing a deep tunnel under high underground water pressure

## Damage of a cutter seal due to high water pressure and large thrust force

- ① Blockade by gravels of sandstone and instantaneous increase of slurry pressure at face
- ② Shortage of capacity of emergency-pressure release device
- ③ Thrust load acting on a cutter drive unit due to excavation of hard rock



砂岩の礫: 一軸強度 = 70~80MPa

## Gravels of sandstone

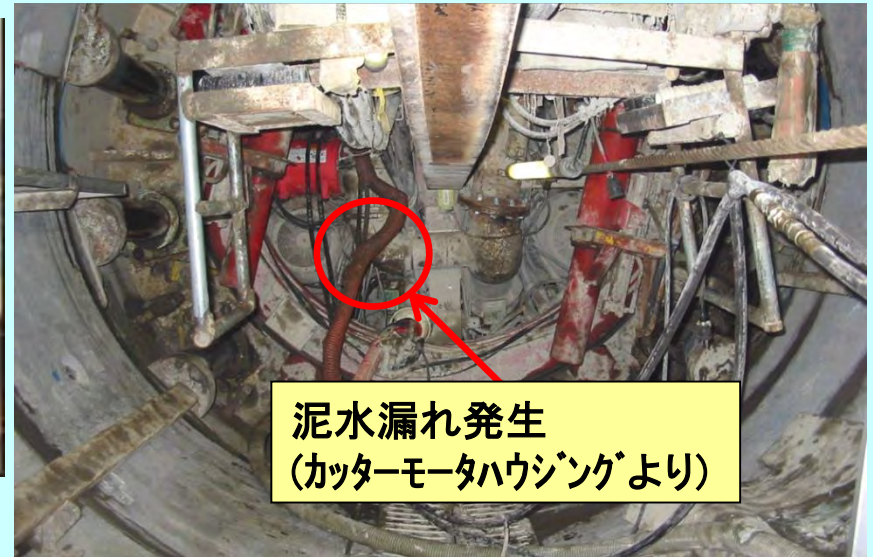

泥水漏れ発生  
(カッターモータハウジングより)

## Leakage of mud slurry

### Countermeasure

- ① Replaced with new cutter seals: Over 1 month
- ② Increased the capacity of emergency-pressure release device, Set sacrifice board
- ③ Set the cutter seal detector unit

# Problems of constructing a deep tunnel under high underground water pressure

## 大深度・高水圧施工の課題②

### Cracks due to large thrust force

- ① Bend of shield jacks due to high thrust force and occurring a horizontal component of a force
- ② Effect of eccentric thrust loads



Cracks due to thrust force

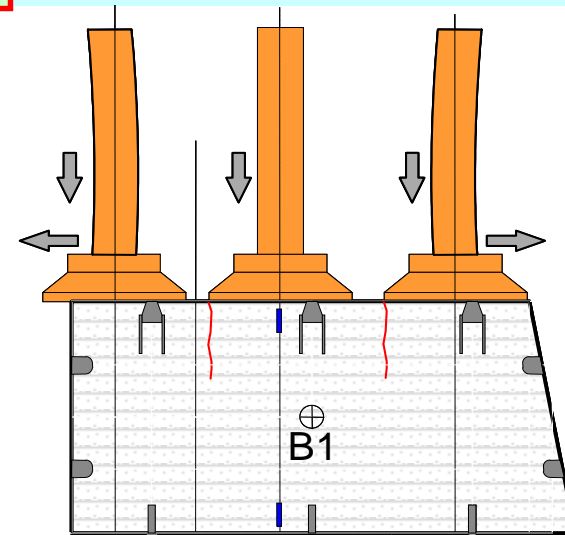

Bend of shield jacks and cracks due to thrust force

### Countermeasure

- ① Loading points of thrust jacks were modified.
- ② The horizontal component of a force was kept under control by setting plates for thrust.

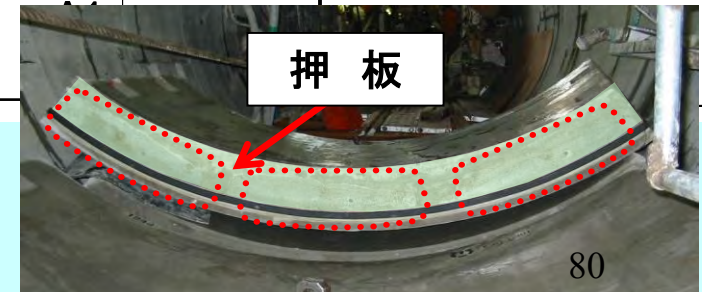

# Continuous Right-angle Excavation Shield Machines

## Continuous vertical and cross excavation shield machine

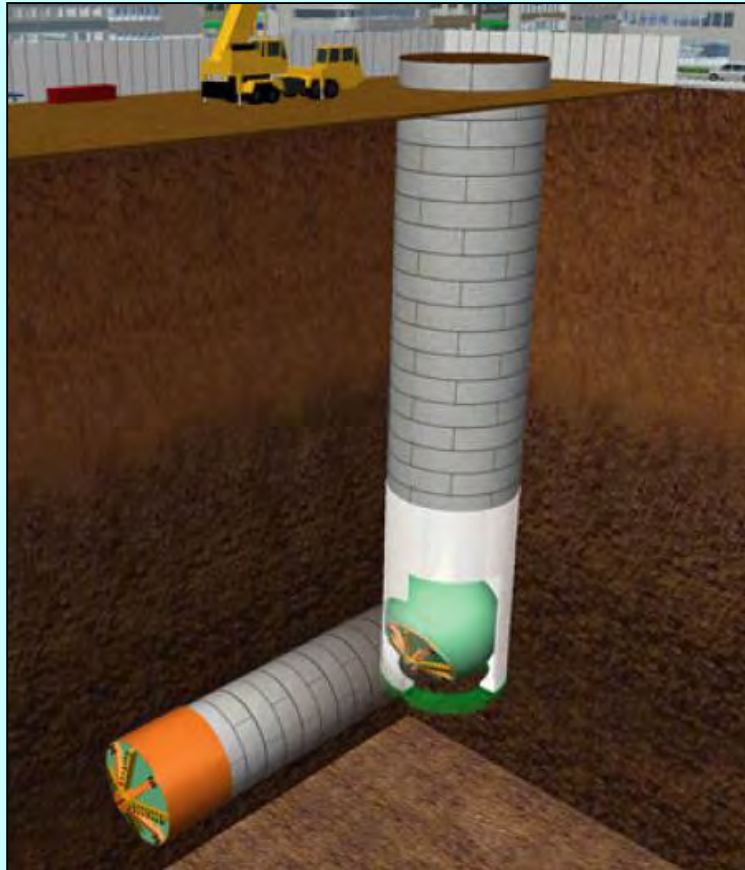

**Continuous vertical  
and cross excavation**

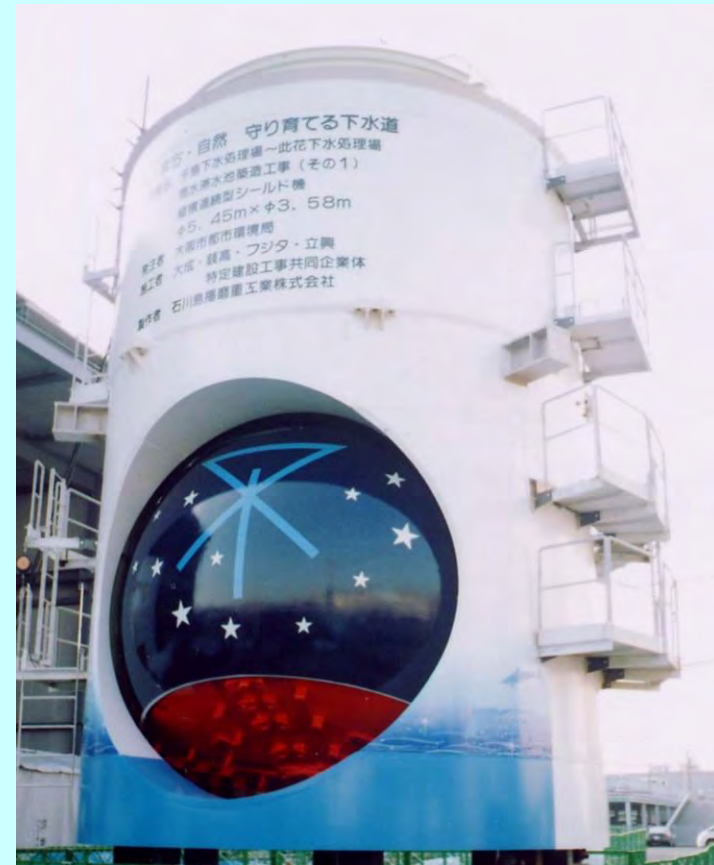

**Continuous vertical and cross  
excavation shield machine**

# Vertical Shield Method

- >Construction method of a shaft.
- >Excavate and advance from to ground surface.

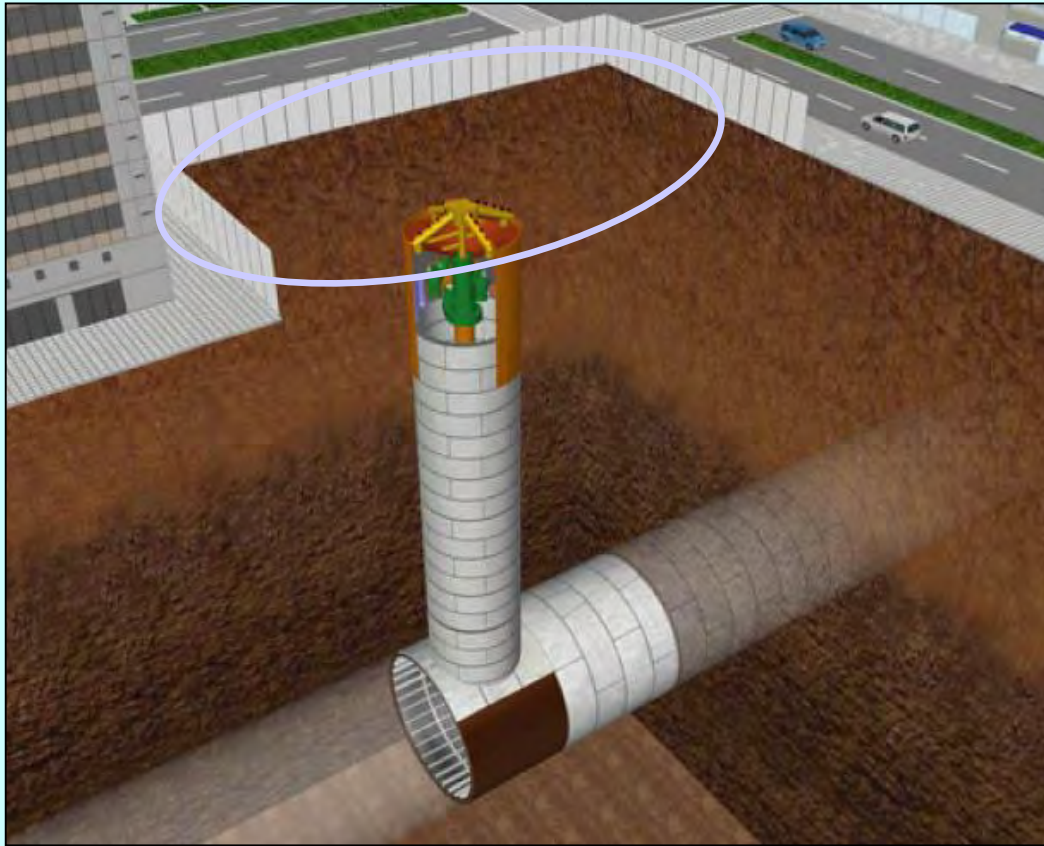
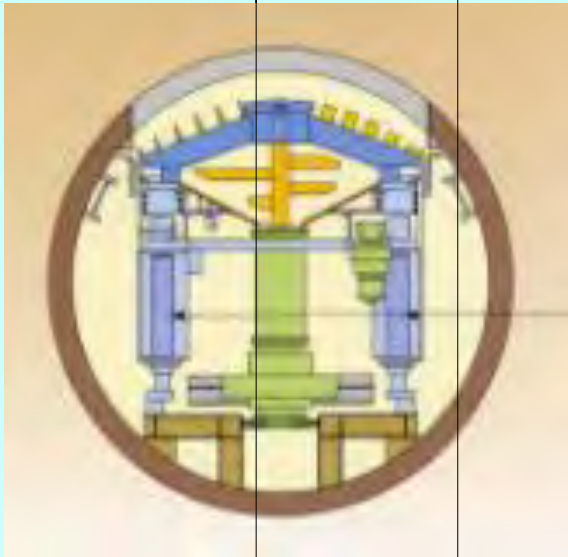

Image of construction by vertical shield method



Vertical shield machine

## Procedure of construction



**Set a vertical shield machine in a tunnel**



**Machining segments at the start point**

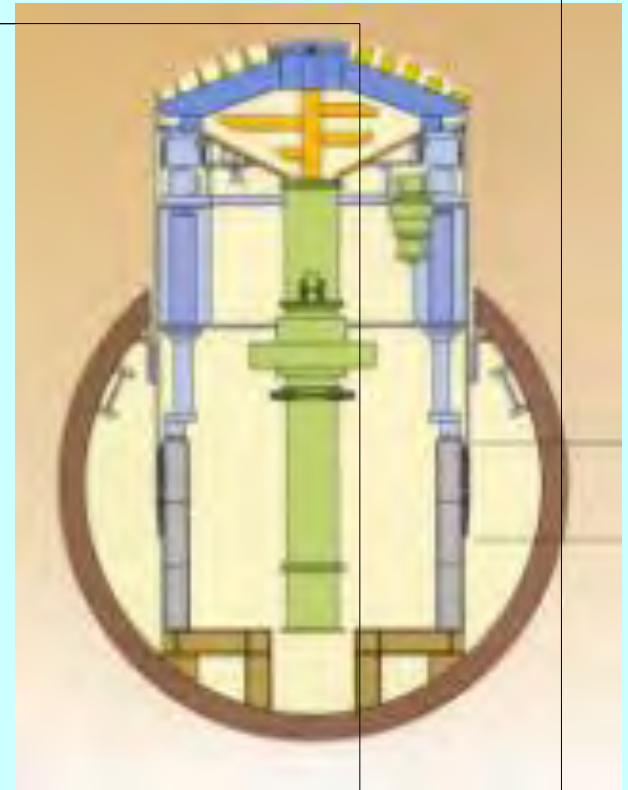

**Completion of assembling a vertical shield machine**

## Set a front body

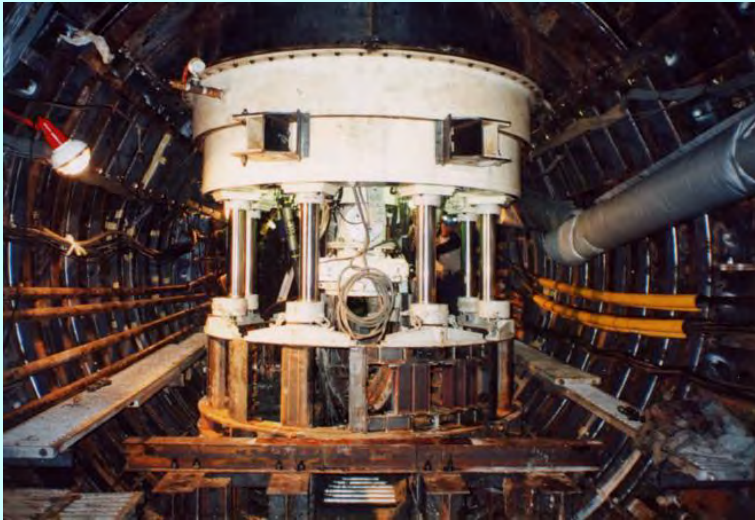

## Assembling a rear body

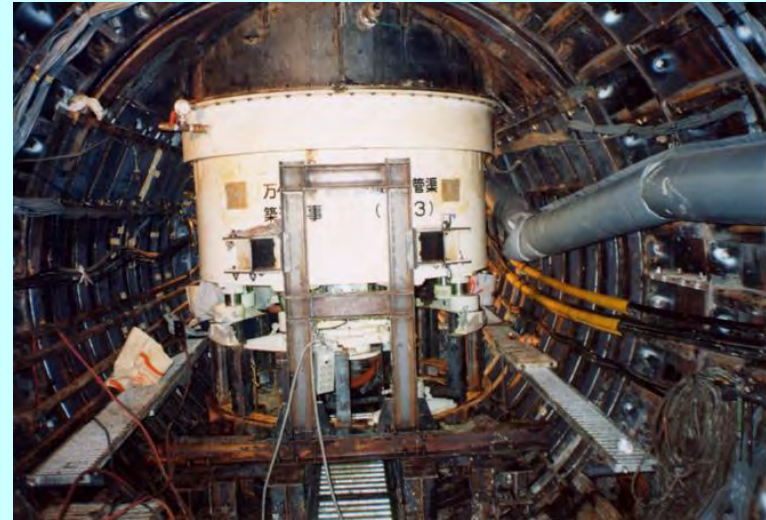

## Completion of assembling



## Arriving



# Vertical Shield Method

An example of construction (3 shafts were constructed by 1 vertical shield machine)

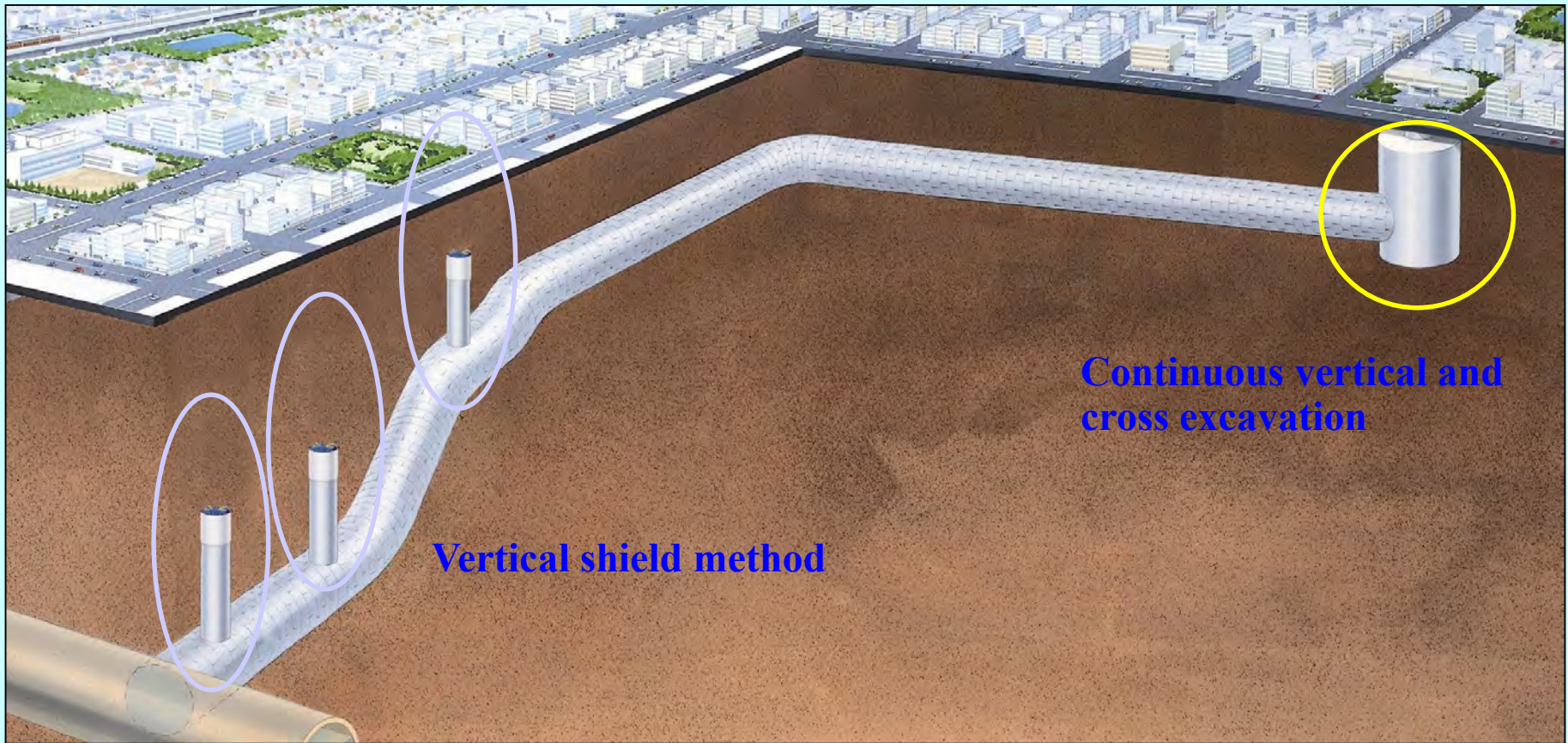

# Specialty shield machines

## Multi circular shield machine (triple type)

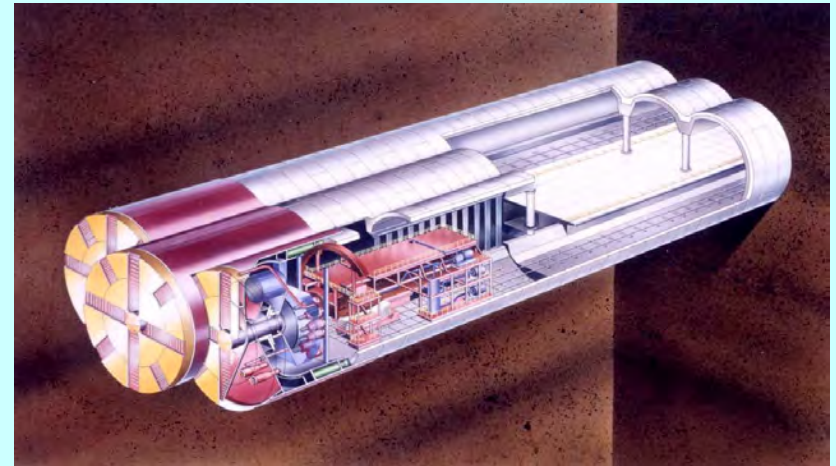
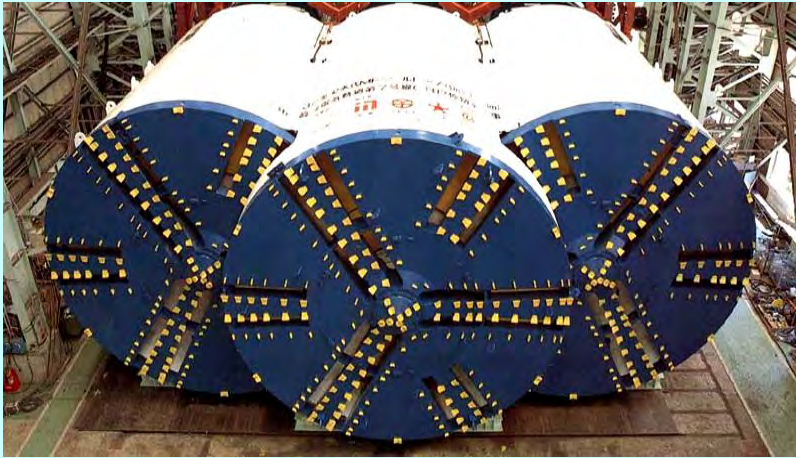

**Mother and child shield machine 12:35~17:16**  
**19:10~25:40**

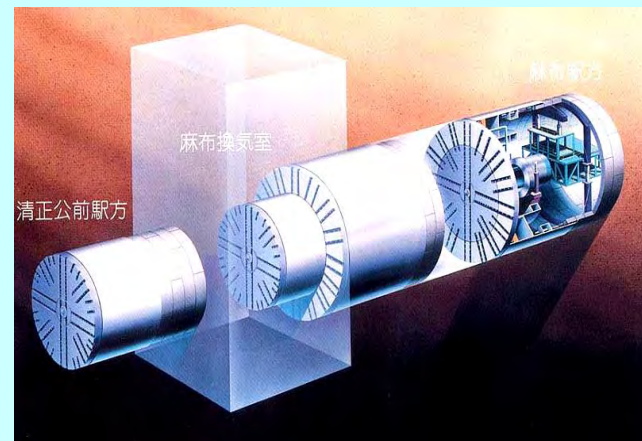
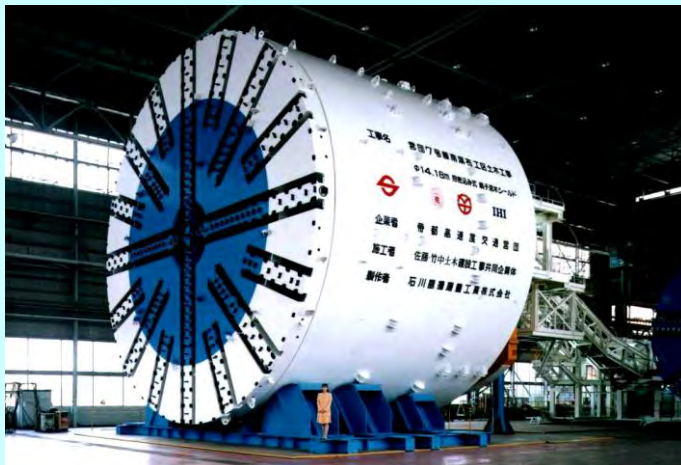

# Contents

- 1. What's a shield tunnel?**
- 2. How to make a shield tunnel?**
- 3. Recent record of shield tunnels in Japan.**
- 4. Design method of a shield tunnel.**
- 5. Examples of shield tunnel projects.**
- 6. SENS method**

# New construction method "SENS" system

## SENS method

New tunnel construction method which is able to improve the **safety**, **economy** and **workability** of the construction.

S: "Shield tunneling method"  
E: "Extruded concrete lining"  
N: "NATM"  
S: "System"

## In SENS method;

- Tunnel: Bored by **TBM**
- Primary lining: **Cast-in-situ concrete** instead of precast segment
- Secondary lining: **Cast-in-situ concrete** for finishing

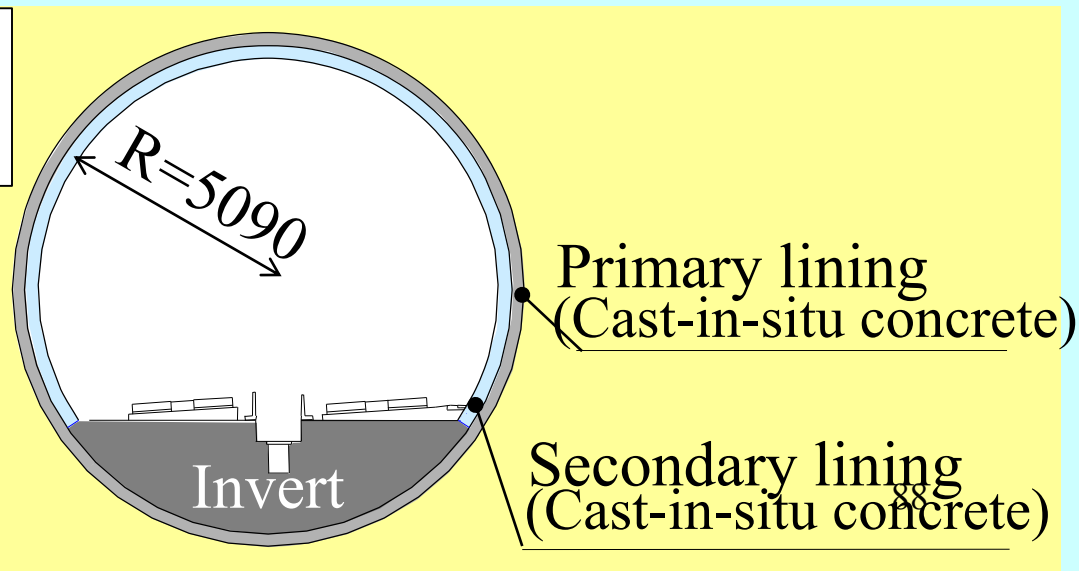
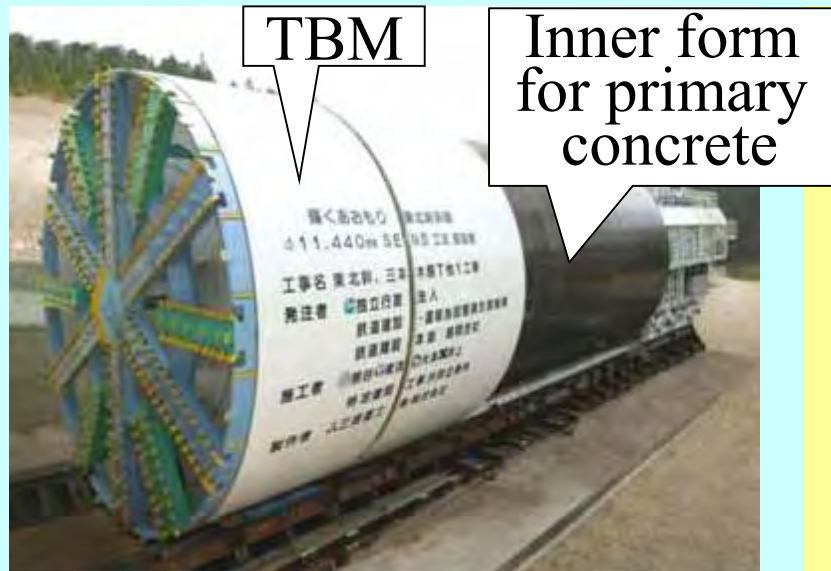

# Facilities of SENS system

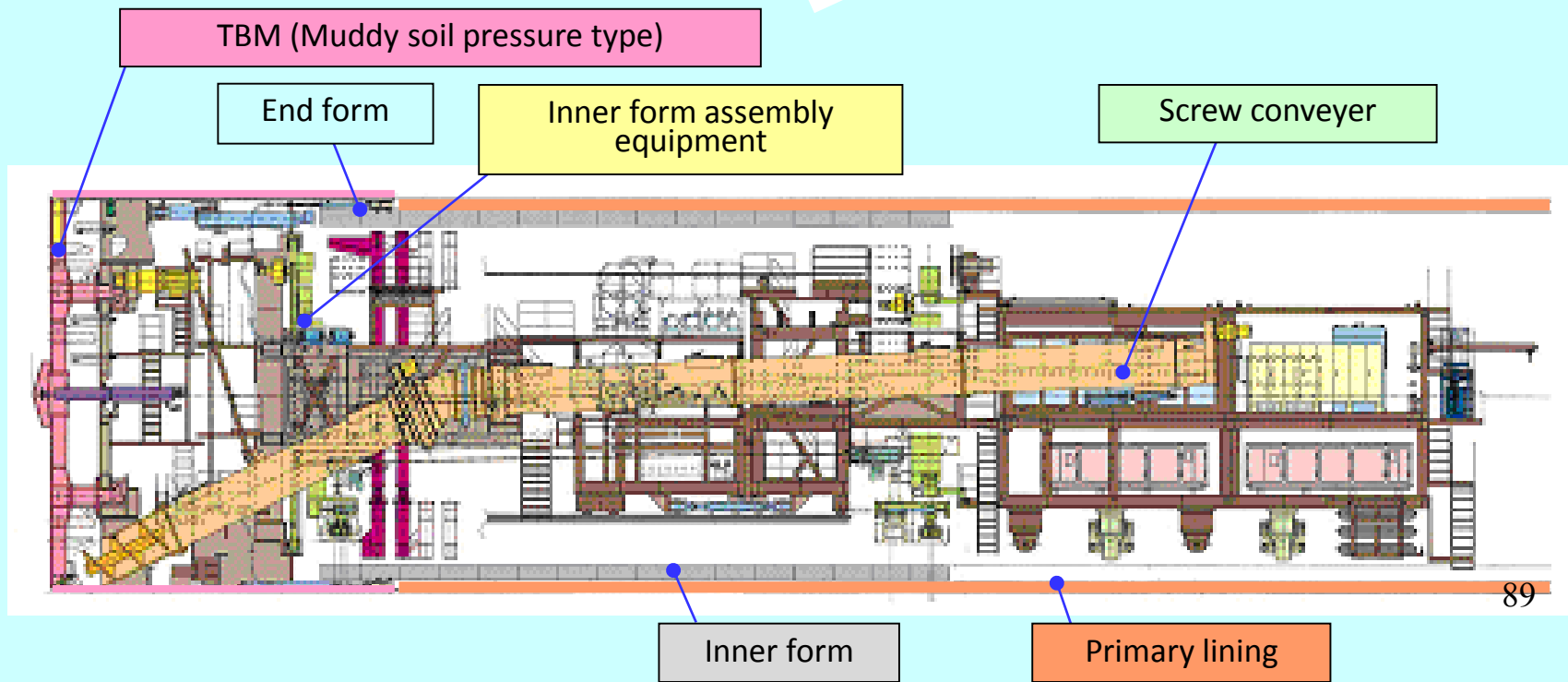
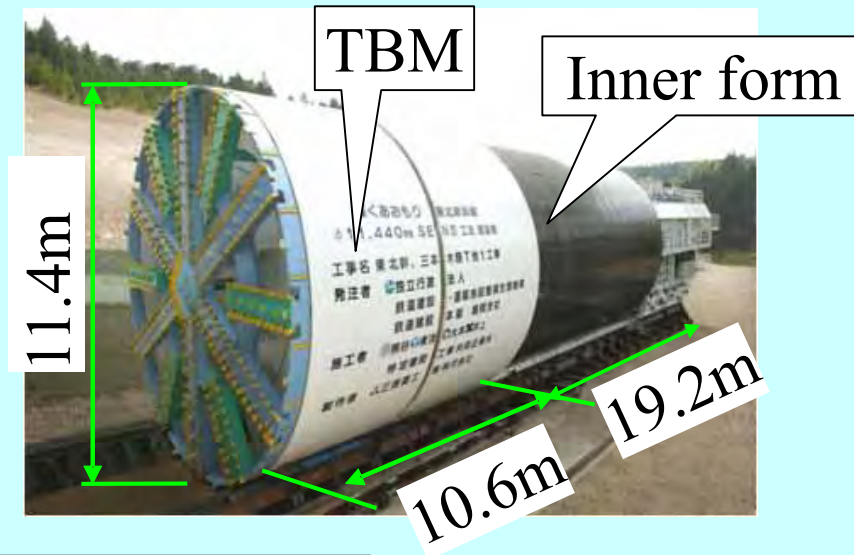

South portal Sambongihara Tunnel L=4,280m North portal

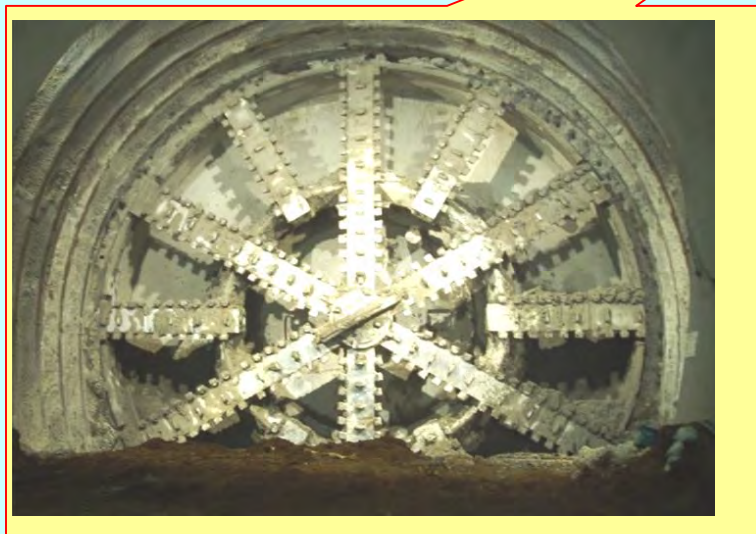
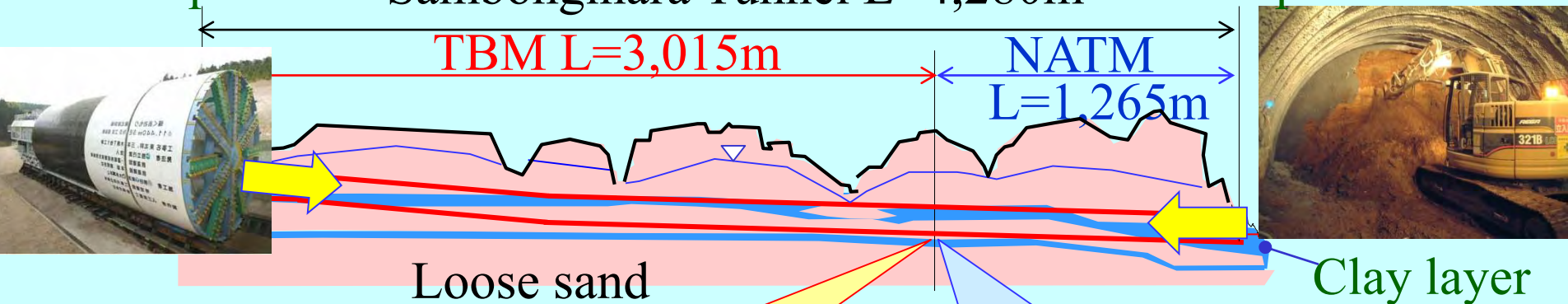

➤ Remaining 3015m was excavated by SENS (TBM) method

➤ Excavation by NATM was terminated on Jul., 2004

➤ Tunnel was bored through in Nov, 2006

# Building process



1. Primary lining

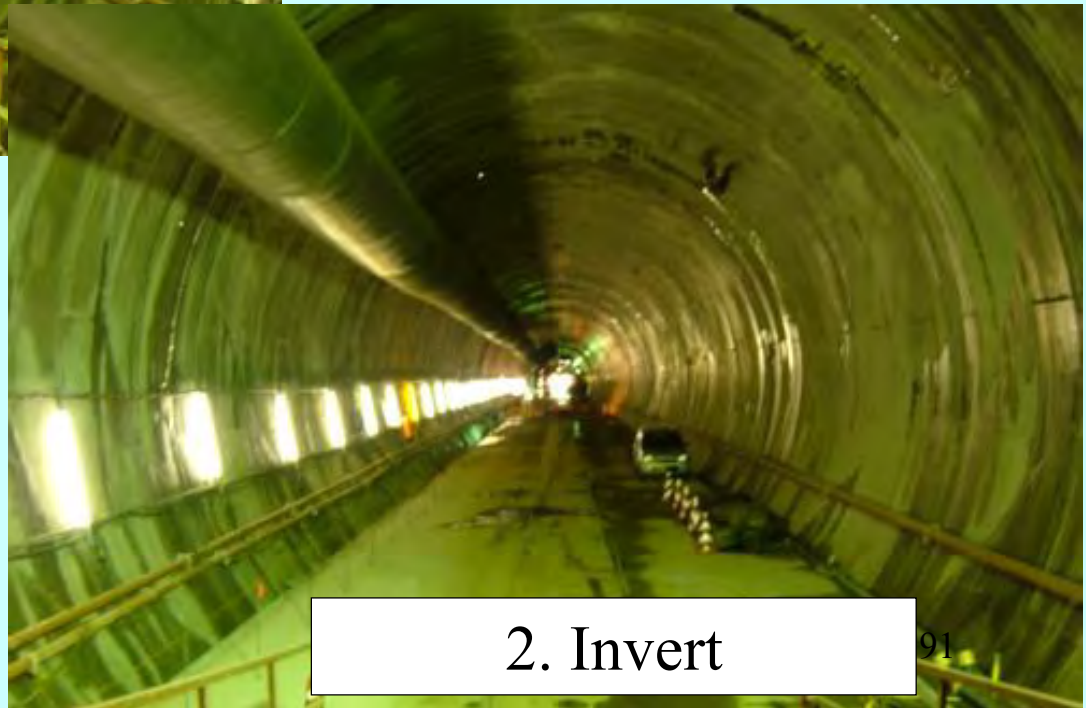

2. Invert

# Building process

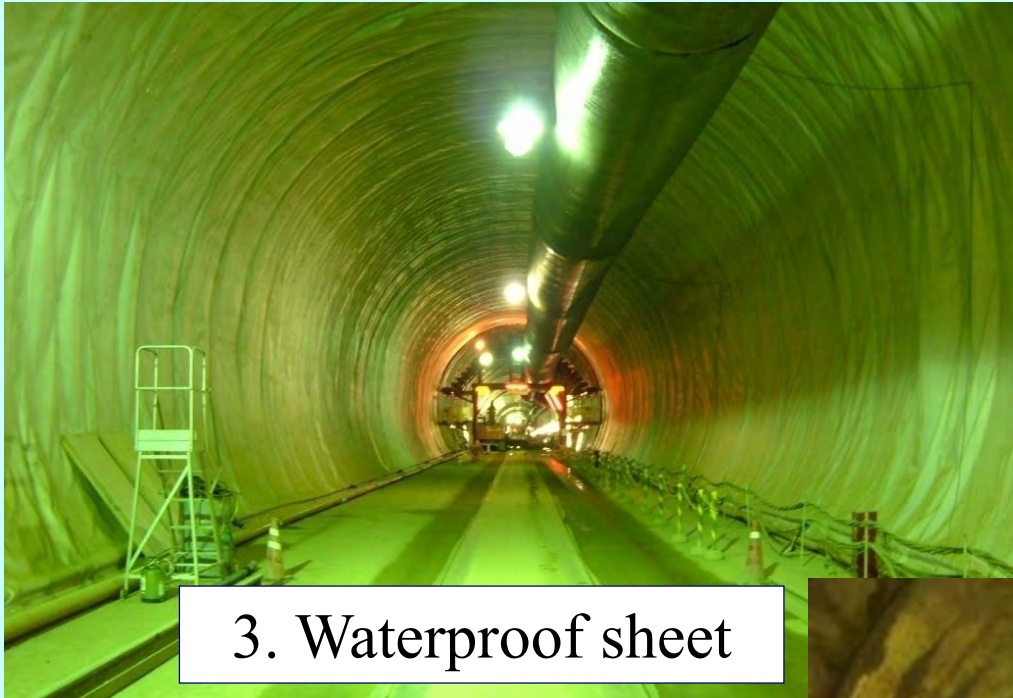

3. Waterproof sheet

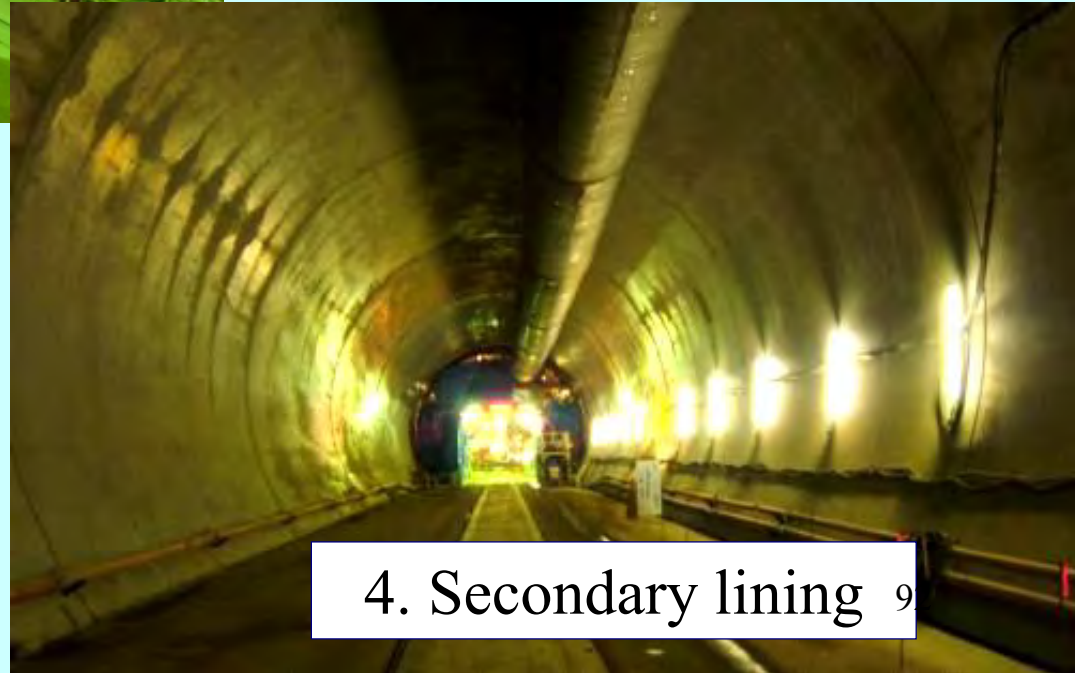

4. Secondary lining 9

# Comparison between NATM and Shield

## Average excavating speed

- **Twice faster** than NATM

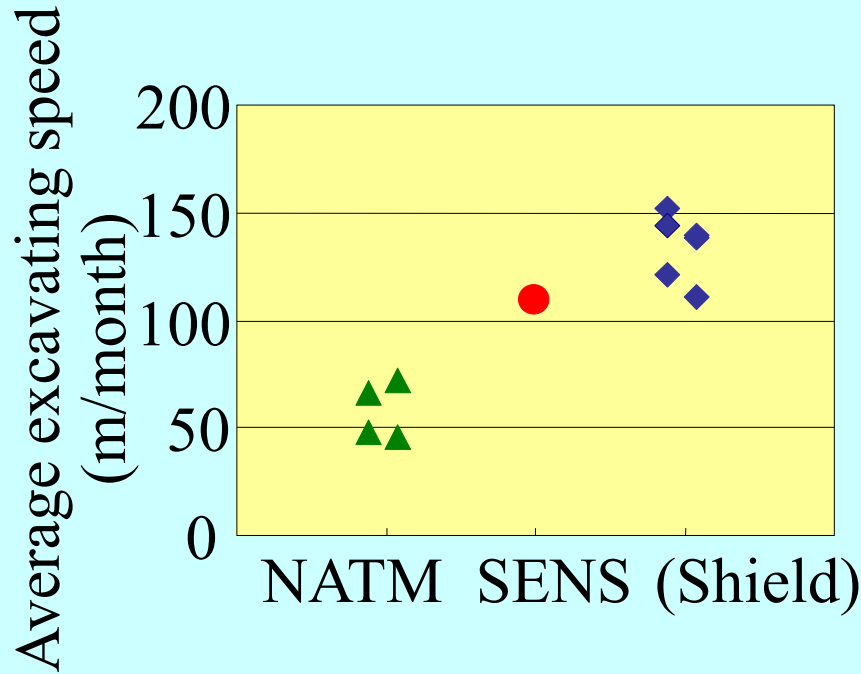

## Construction cost

- Cost of construction for unit excavation volume is **almost the same**

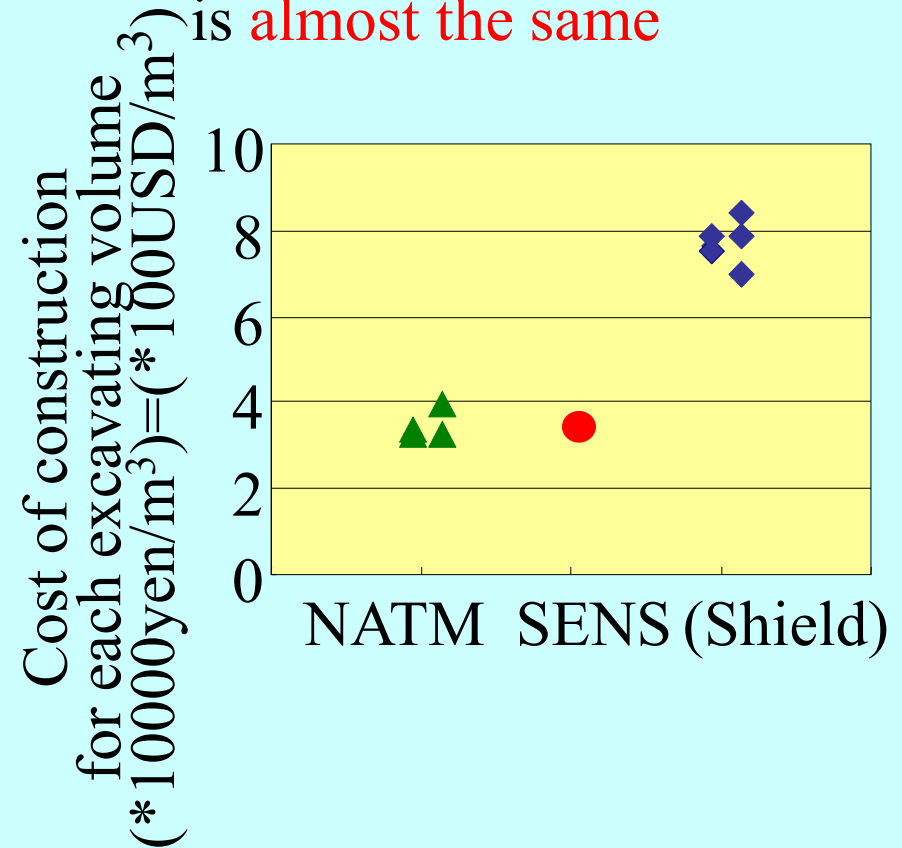

➡ SENS method is effective in improving the excavating speed.

# Conclusion

## SENS method

- Having a **good performance** in Sambongihara Tunnel
- Applied to **Tsugaru-Yomogita Tunnel** of the Hokkaido Shinkansen Line

## Tsugaru-Yomogita tunnel

- Tunnel cover is shallow.
- Ground is a diluvial loose sand and the ground water level is high. } throughout the tunnel
- **6 tunnels were brought together in one** tunnel.

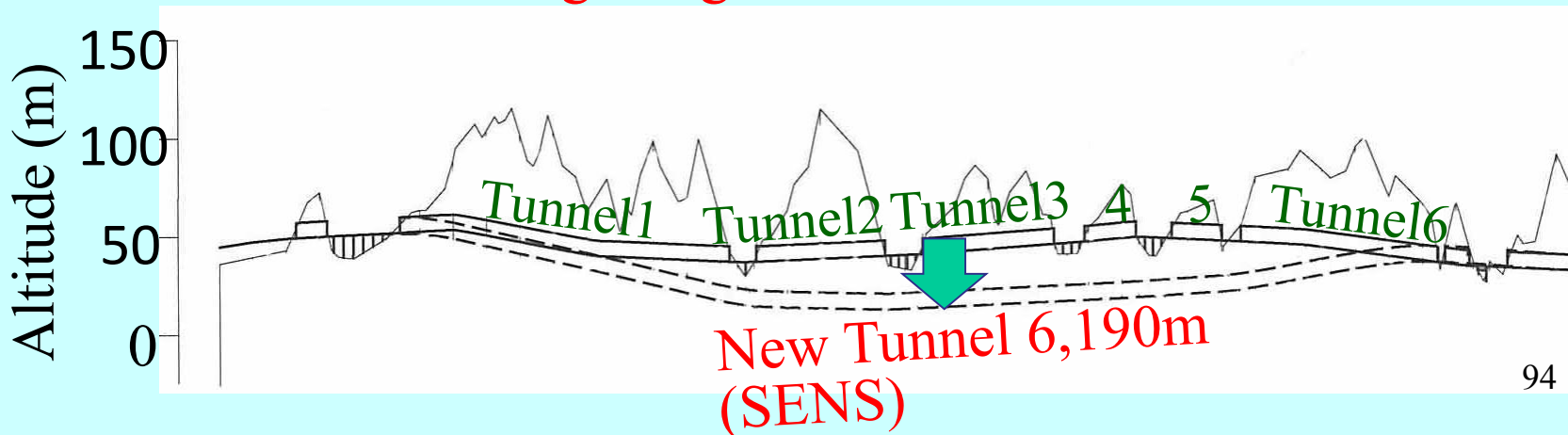

# My advice for engineer (on a construction site)

---

1. Feel strangeness at a glance. ➡ >Knowledge, Experience  
(look at various construction sites.)
2. Think ahead. ➡ >Predict possible troubles. ➡ >Avoid troubles.  
>Preparation for taking countermeasures to the troubles.
3. Simple is the best. ➡ >Complexness causes accidents.
4. Time is money. ➡ >Decide quickly how to cope with a trouble when it happen.  
>Buy time.  
>After that, modified the countermeasure with observing the situation.

(If the possibility that a countermeasure will succeed is over 50%, you have to go ahead.)

5. Imagination is very important. ➡ >Image what's happen and how does it happen in the blind spaces.